

NEW SURVEY
OF EXISTING PARCEL
RICHLAND COUNTY
TAX MAP OFFICE
EAK 3-18-25
INITIAL & DATE
RR-67

LINE	BEARING	DISTANCE
L-1	N 88°31'55" E	23.20'

CURVE	RADIUS	ARC LENGTH	CHORD LENGTH	CHORD BEARING	DELTA ANGLE
C1	397.91'	169.30'	168.03'	N 12°07'24" W	24°22'42"
C2	5679.65'	50.03'	50.03'	S 41°22'55" E	0°30'17"

- LEGEND**
- IRON PIN FOUND
 - ⊘ IRON PIPE FOUND
 - IRON PIN SET-5/8" REBAR SET WITH I.D. CAP STAMPED "RAMSEY S-8396"

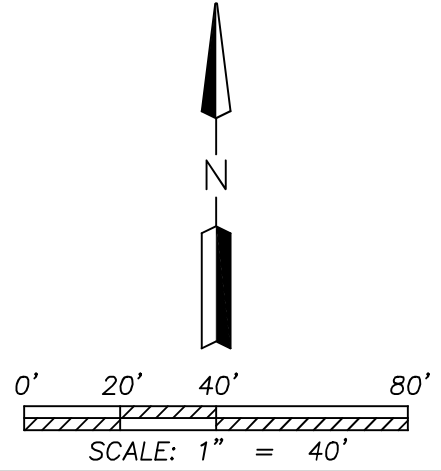

Distances shown hereon are expressed in feet and decimal parts thereof.

Bearings are to an assumed meridian and are used to express angles only.

CERTIFICATION: I hereby state that the foregoing survey was prepared from actual field measurements, in accordance with Chapter 4733-37, Ohio Administrative Code.

By: *Nathaniel B. Ramsey* 02/28/2025
Nathaniel B. Ramsey, P.S. #8396 Date
For Ramsey Surveying

RAMSEY SURVEYING
Professional Land Surveying Services
283 Eby Road
Shiloh, Ohio 44878
TEL (419) 512-2596 FAX (419) 522-0399
EMAIL nramsey@ramsey-surveying.com

SURVEY MADE FOR PROPERTY TRANSFER
BEING LOT 3609, LOT 3608, AND PART OF LOT 3607
PLAT VOL 23, PAGE 86
IN THE CITY OF SHELBY
RICHLAND COUNTY, OHIO

DRAWN SDS	CHECKED NBR	SCALE 1" = 40'	DATE 02/28/2025
JOB NO: SM-6158			SHEET 1 OF 1

RAMSEY SURVEYING
Professional Land Surveying Services

283 Eby Road
Shiloh, Ohio 44878
TEL (419) 512-2596
FAX (419) 522-0399
EMAIL nramsey@ramsey-surveying.com

LEGAL DESCRIPTION

**LOT #3609, LOT #3608, AND PART OF LOT #3607
CITY OF SHELBY
RICHLAND COUNTY, OHIO**

February 28, 2025

Situated in the City of Shelby, County of Richland, State of Ohio and being Lot #3609, Lot #3608, and part of Lot #3607, recorded in plat volume 23, page 86, conveyed to Bruce J. Metzger by deed volume 864, page 123, official record volume 205, page 113 and official record volume 205, page 115, being more particularly described as follows:

Beginning for the same at an iron pin set in the northerly corner of Lot #3607, the northern corner of a parcel conveyed to Gage Wright by official record volume 2997, page 5942, said iron pin also being on the southerly existing right of way line of the Ashland Railway-(100' R/W);

Thence, the following **SIX** courses:

1. **South 63 degrees 41 minutes 41 seconds West, 127.13 feet** along the northerly line of said Wright parcel to a point in the northwesterly corner thereof, being on the easterly existing right of way line of Martin Drive-(50' R/W), and passing through an iron pin found at 126.73 feet;
2. Along a curve to the right with a **radius of 397.91 feet, an arc length of 169.30 feet, a delta angle of 24 degrees 22 minutes 42 seconds, a chord bearing North 12 degrees 07 minutes 24 seconds West, and a chord length of 168.03 feet** along said easterly existing right of way line of Martin Drive to an iron pin set marking a point of tangency;
3. **North 00 degrees 03 minutes 56 seconds East, 35.45 feet** continuing along said easterly existing right of way line of Martin Drive to an iron pin set in the northwest corner of the aforementioned Lot #3609;
4. **North 88 degrees 31 minutes 55 seconds East, 23.20 feet** along the north line of said Lot #3609 to an iron pipe found in the northeast corner thereof, and being on the aforementioned southerly existing right of way line of the Ashland Railway;
5. Along a curve to the right with a **radius of 5679.65 feet, an arc length of 50.03 feet, a delta angle of 00 degrees 30 minutes 17 seconds, a chord bearing South 41 degrees 22 minutes 55 seconds East, and a chord length of 50.03 feet** along said southerly existing right of way line of the Ashland Railway to an iron pin set marking a point of tangency;

6. **South 41 degrees 07 minutes 46 seconds East, 141.31 feet** continuing along said southerly existing right of way line of the Ashland Railway to the **Place of Beginning**, containing a total of 15,735 square feet, of which 8565 square feet is within Lot #3609, 6787 square feet is within Lot #3608, and 383 square feet is within said part Lot #3607, more or less, and subject to all legal highways, leases, servitudes, use restrictions, and easements of record.

Bearings are based on an assumed meridian and are used to express angles only.

According to a survey made in February 2025 by Nathaniel B. Ramsey, Ohio Registered Professional Surveyor No. 8396.

Nathaniel B. Ramsey
Professional Surveyor No. 8396
For Ramsey Surveying
SM-6158_Legal.docx



NEW SURVEY
OF EXISTING PARCEL
RICHLAND COUNTY
TAX MAP OFFICE

EAK 3-18-25

INITIAL & DATE

RR-67