

JOSEPH R. & LEANNA E. CURRY
ORV. 2380, PG. 726

KIMBERLY A. HALE
ORV. 2740, PG. 289

SURVEY FOR PROPERTY
TRANSFER
0.3443 ACRES
14,999.75 SQ. FT.

NEW SURVEY
OF EXISTING PARCEL
RICHLAND COUNTY
TAX MAP OFFICE
EAK 10-31-24

INITIAL & DATE
QQ-313

THE MILLER FAMILY TRUST
DATED JULY 7, 2022
ORV. 3004, PG. 2575

- LEGEND**
- IRON PIN FOUND
 - △ MAGNAIL SPIKE FOUND
 - ✕ 2" MAGNAIL SPIKE SET IN CONCRETE DRIVEWAY
 - IRON PIN SET-5/8" REBAR SET WITH I.D. CAP STAMPED "RAMSEY S-8396"

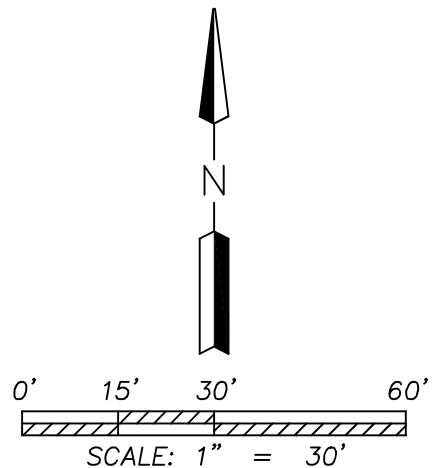

Distances shown hereon are expressed in feet and decimal parts thereof.

Bearings are to an assumed meridian and are used to express angles only.

CERTIFICATION: I hereby state that the foregoing survey was prepared from actual field measurements, in accordance with Chapter 4733-37, Ohio Administrative Code.

By: *Nathaniel B. Ramsey* 10/17/2024
Nathaniel B. Ramsey, P.S. #8396 Date
For Ramsey Surveying

RAMSEY SURVEYING
Professional Land Surveying Services

283 Eby Road
Shiloh, Ohio 44878
TEL (419) 512-2596 FAX (419) 522-0399
EMAIL nramsey@ramsey-surveying.com

**SURVEY MADE FOR PROPERTY
TRANSFER**

**PART OF THE NORTHEAST QUARTER
OF SECTION 15, WASHINGTON TOWNSHIP
T-20 N, R-18 W
RICHLAND COUNTY, OHIO**

| | | | |
|-----------------|----------------|-------------------|--------------------|
| DRAWN HCG | CHECKED NBR | SCALE 1" = 30' | DATE 10/17/2024 |
| JOB NO: SM-6094 | | | SHEET 1 OF 1 |

LEGAL DESCRIPTION

October 17, 2024

Situated in the Township of Washington, County of Richland, State of Ohio, being a part of the Northeast Quarter of Section 15, Township 20-North, Range 18-West and being a parcel conveyed to Kimberly A. Hale by official record volume 2740 page 289 of the Richland County Recorder's records and being more particularly described as follows:

Commencing at an iron pin found and accepted as marking the northeast corner of said Quarter, and being on the centerline of East Hanley Road-(C.H. 139)(60' R/W);

Thence, **South 89 degrees 50 minutes 50 seconds West, 2186.42 feet** along the north line of said Quarter, said centerline of East Hanley Road to a point in a northwest corner of a parcel conveyed to The Miller Family Trust, dated July 7, 2022, by official record volume 3004, page 2575, said point also being the **Place of Beginning** of the parcel herein described;

Thence, the following **FOUR** courses:

1. **South 00 degrees 29 minutes 21 seconds East, 200.00 feet** along a west line of said Miller Family Trust parcel to an iron pin set in an interior corner thereof, passing through an iron pin set for reference at 30.00 feet;
2. **South 89 degrees 50 minutes 50 seconds West, 75.00 feet** along a north line of said Miller Family Trust parcel to an iron pin found in the southeast corner of a parcel conveyed to Joseph R. and Leanna E. Curry by official record volume 2380, page 726;
3. **North 00 degrees 29 minutes 21 seconds West, 200.00 feet** along the east line of said Curry parcel to a point in the northeast corner thereof, and being on the aforementioned north line of the Northeast Quarter, the aforementioned centerline of East Hanley Road, and passing through a 2" Magnail spike set, in a concrete driveway, for reference at 170.00 feet;
4. **North 89 degrees 50 minutes 50 seconds East, 75.00 feet** along said north line of the Northeast Quarter, said centerline of East Hanley Road to the **Place of Beginning**, and containing 0.3443 of an acre (14,999.75 Sq. Ft.), more or less, and subject to all legal highways, leases, servitudes, use restrictions, and easements of record.

Bearings are based on an assumed meridian and are used to express angles only.

Iron pins set are 5/8" rebar with cap stamped "Ramsey S-8396"

According to a survey made in October 2024 by Nathaniel B. Ramsey, Ohio Registered Professional Surveyor No. 8396.

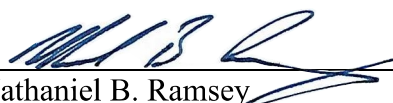
Nathaniel B. Ramsey
Professional Surveyor No. 8396
For Ramsey Surveying
SM-6094_Legal.docx



NEW SURVEY
OF EXISTING PARCEL
RICHLAND COUNTY
TAX MAP OFFICE

EAK 10-31-24

INITIAL & DATE

QQ-313