

WEST SECOND STREET-(60')

NEW SURVEY
OF EXISTING PARCEL
RICHLAND COUNTY
TAX MAP OFFICE

EAK 9-18-24

INITIAL & DATE

QQ-269

LEGEND

- IRON PIPE FOUND
- △ DRILL HOLE FOUND IN BRICK DRIVEWAY
- ⊗ 5/8" IRON PIN FOUND WITH I.D. CAP MARKED "BLUNK 6320"
- IRON PIN SET-5/8" REBAR SET WITH I.D. CAP STAMPED "RAMSEY S-8396"

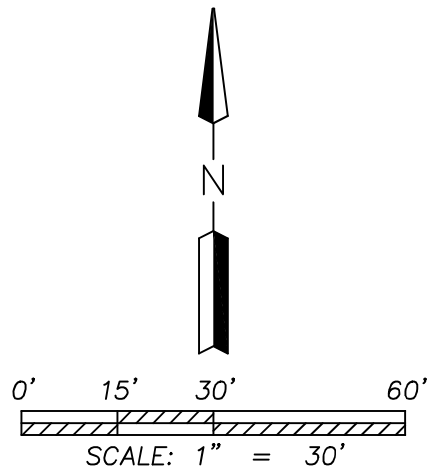

Distances shown hereon are expressed in feet and decimal parts thereof.

Bearings are to an assumed meridian and are used to express angles only.

CERTIFICATION: I hereby state that the foregoing survey was prepared from actual field measurements, in accordance with Chapter 4733-37, Ohio Administrative Code.

By: Nathaniel B. Ramsey, P.S. #8396
For Ramsey Surveying

08/30/2024
Date

RAMSEY SURVEYING
Professional Land Surveying Services

283 Eby Road
Shiloh, Ohio 44878
TEL (419) 512-2596 FAX (419) 522-0399
EMAIL nramsey@ramsey-surveying.com

SURVEY MADE FOR PROPERTY TRANSFER

BEING LOT #4167 AND PART OF LOT #4168 RECORDED IN PLAT BOOK 5 PAGE 21, CITY OF MANSFIELD, RICHLAND COUNTY, OHIO

DRAWN SDS	CHECKED NBR	SCALE 1" = 30'	DATE 08/30/2024
JOB NO: SM-6046			SHEET 1 OF 1

RAMSEY SURVEYING
Professional Land Surveying Services

283 Eby Road
Shiloh, Ohio 44878
TEL (419) 512-2596
FAX (419) 522-0399
EMAIL nramsey@ramsey-surveying.com

LEGAL DESCRIPTION

August 30, 2024

Situated in the State of Ohio, County of Richland, City of Mansfield; being Lot 4167 and part of Lot 4168 of the consecutively numbered lots in said city, as recorded in plat book 5, page 21, and being a parcel conveyed to Piper's Rental Properties, LLC. by official record volume 3019, page 1470 of the Richland County Recorder's records, and being more particularly described as follows:

Beginning for the same at an iron pipe found and accepted as marking the southeast corner of said Lot 4167, also being on the north existing right of way line of West Second Street-(60' R/W);

Thence, the following **FOUR** Courses:

1. **North 86 degrees 57 minutes 23 seconds West, 67.83 feet** along the south line of said Lot 4167, the south line of Lot 4168, also being the north line of West Second Street to a point in the southeast corner of a parcel conveyed to James Allen Todd and Rebecca Dawn Todd by official record volume 3018, page 1655 and being referenced by a drill hole found in brick driveway South 24 degrees 19 minutes 30 seconds East, 0.18 feet therefrom;
2. **North 03 degrees 17 minutes 24 seconds East, 125.00 feet**, along the east line of said Todd parcel to an iron pin found in the northeast corner thereof, said iron pin also being on the south line of Lot 4166;
3. **South 86 degrees 57 minutes 35 seconds East, 67.62 feet** along the south line of said Lot 4166 to an iron pin set in the southeast corner thereof, also being on the west line of Lot 2972;
4. **South 03 degrees 11 minutes 33 seconds West, 125.00 feet**, along the west line of said Lot 2972 and the west line of Lot 2974 to the **Place of Beginning**, and containing a total of 8466.24 square feet, more or less, of which 6403.69 sf is located within said Lot 4167 and 2062.55 sf is located within said Part Lot 4168 and subject to all legal highways, easements, leases, and use restrictions of record.

Bearings are based on an assumed meridian and are used to express angles only.

Iron pins set are 5/8" rebar with I.D. cap stamped "Ramsey S-8396"

According to a survey made in August 2024 by Nathaniel B. Ramsey, Ohio Registered Professional Surveyor No. 8396.

NEW SURVEY
OF EXISTING PARCEL
RICHLAND COUNTY
TAX MAP OFFICE
EAK 9-18-24
INITIAL & DATE
QQ-269

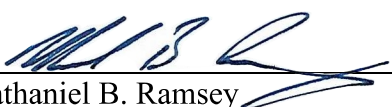
Nathaniel B. Ramsey
Professional Surveyor No. 8396
For Ramsey Surveying
SM-6046 Legal.docx

