

November 15, 2022

**LEGAL DESCRIPTION**

**Situated** in the Township of Madison, County of Richland, State of Ohio, and being a part of Lot 124 and part of Lot 122, Lincoln Heights Allotment, as shown on plat volume 11, page 7, being more particularly described as follows:

**Beginning** for the same at an iron pipe found and accepted as marking the southeast corner of Lot 124 and being on the north right of way line of Ashland Road-(US Route 42) (60' R/W);

Thence, the following **FIVE** courses:

1. **North 05 degrees 20 minutes 10 seconds West, 176.97 feet** traversing aforementioned Lot 124 and aforementioned lot 122 to an iron pin set;
2. **North 86 degrees 41 minutes 05 seconds East, 62.22 feet** traversing said Lot 122 to an iron pin set on the east line of said Lot 122;
3. **South 00 degrees 50 minutes 14 seconds East, 25.91 feet** along said east line of Lot 122 to an iron pin found in the southeast corner thereof, said iron pin also being in the northeast corner of aforementioned Lot 123;
4. **South 89 degrees 26 minutes 03 seconds West, 47.80 feet** along the north line of said Lot 123 to a point in the northwest corner thereof, passing through an iron pipe found for reference at 46.75 feet;
5. **South 00 degrees 39 minutes 22 seconds East, 153.44 feet** along the west line of said Lot 123 to the **Place of Beginning** and containing a total of 2,460.73 Sq. Ft., of which 1,496.95 Sq. Ft. are located within said Part Lot 122 and 963.78 Sq. Ft. are located within said Part Lot 124, more or less, and subject to all legal highways, easements, leases, servitudes, and use restrictions of record.

Bearings are to an assumed meridian and are used to express angles only.

Iron pins set are 5/8" rebar with plastic cap stamped "Ramsey S-8396".

According to a survey made in November, 2022 by Nathaniel B. Ramsey, Ohio Registered Professional Surveyor No. 8396.

Prior Deed Reference: official record volume 2980, page 284  
official record volume 2981, page 379

  
\_\_\_\_\_  
Nathaniel B. Ramsey  
Professional Surveyor No. 8396  
For Ramsey Surveying  
SM-5781\_LEGAL



NEW SPLIT  
RICHLAND COUNTY  
TAX MAP OFFICE  
**EAK 12-2-22**  
\_\_\_\_\_  
INITIAL & DATE  
**OO-403**

**SURVEY FOR PROPERTY TRANSFER**  
**2,460.73 SQ. FT. TOTAL**

STEVE BEATTY, SR.  
 ORV. 2980, PG. 284  
 LOT #122

N 86°41'05" E 62.22'

(1496.95 Sq. Ft.)

S 89°26'03" W 47.80'

S 00°50'14" E  
 25.91'

REF=1.05'

PART LOT #124

PART LOT #124

176.97'

N 05°20'10" W

(415.61 Sq. Ft.)

S 00°39'22" E 153.44'

LOT #123

LOT #90

STEVE BEATTY, SR. & JOAN BEATTY  
 ORV. 2981, PG. 379

PART LOT #124

NEW SPLIT  
 RICHLAND COUNTY  
 TAX MAP OFFICE  
**EAK 12-2-22**

INITIAL & DATE  
**00-403**

ASHLAND ROAD—(US ROUTE 42)(60')

EX R/W

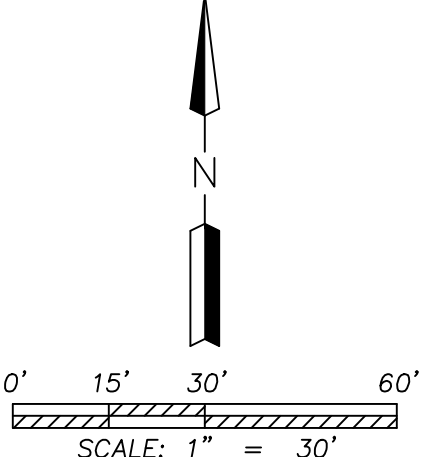

**LEGEND**

- IRON PIN FOUND
- ∅ IRON PIPE FOUND
- IRON PIN SET—5/8" REBAR SET WITH I.D. CAP STAMPED "RAMSEY S-8396"

Distances shown hereon are expressed in feet and decimal parts thereof.

Bearings are to an assumed meridian and are used to express angles only.

CERTIFICATION: I hereby state that the foregoing survey was prepared from actual field measurements, in accordance with Chapter 4733-37, Ohio Administrative Code.

By: Nathaniel B. Ramsey, P.S. #8396 Date: 11/15/2022  
 For Ramsey Surveying

**RAMSEY SURVEYING**  
 Professional Land Surveying Services

283 Eby Road  
 Shiloh, Ohio 44878  
 TEL (419) 512-2596 FAX (419) 522-0399  
 EMAIL nramsey@ramsey-surveying.com

**SURVEY MADE FOR PROPERTY TRANSFER**

**PART OF LOTS 124 & 122  
 IN LINCOLN HEIGHTS ALLOTMENT  
 PLAT VOL. 11, PG. 7  
 IN MADISON TOWNSHIP  
 RICHLAND COUNTY, OHIO**

DRAWN HCG	CHECKED NBR	SCALE 1" = 30'	DATE 11/15/2022
JOB NO: SM-5781			SHEET 1 OF 1