

NEW SURVEY
 OF EXISTING PARCEL
 RICHLAND COUNTY
 TAX MAP OFFICE
EAK 10-24-22

INITIAL & DATE
OO-355

- LEGEND**
- IRON PIN FOUND
 - △ IRON PIPE FOUND
 - IRON PIN SET--5/8" REBAR
 SET WITH I.D. CAP STAMPED
 "RAMSEY S-8396"

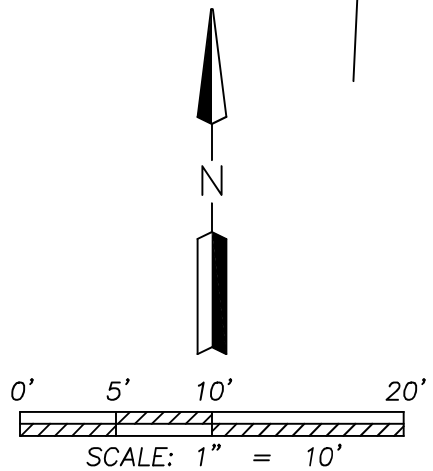

Distances shown hereon are expressed in feet and decimal parts thereof.

Bearings are to an assumed meridian and are used to express angles only.

CERTIFICATION: I hereby state that the foregoing survey was prepared from actual field measurements, in accordance with Chapter 4733-37, Ohio Administrative Code.

By: Nathaniel B. Ramsey 09/30/2022
 Nathaniel B. Ramsey, P.S. #8396 Date
 For Ramsey Surveying

RAMSEY SURVEYING
 Professional Land Surveying Services

283 Eby Road
 Shiloh, Ohio 44878
 TEL (419) 512-2596 FAX (419) 522-0399
 EMAIL nramsey@ramsey-surveying.com

SURVEY MADE FOR PROPERTY TRANSFER

**BEING S.D. 2 OF LOT 457
 OF THE CONSECUTIVELY NUMBERED LOTS
 IN THE CITY OF MANSFIELD
 RICHLAND COUNTY, OHIO**

DRAWN HCG	CHECKED NBR	SCALE 1" = 10'	DATE 09/30/2022
JOB NO: SM-5761			SHEET 1 OF 1

September 30, 2022

LEGAL DESCRIPTION

Situated in the City of Mansfield, County of Richland, State of Ohio, S.D. 2 of Lot 457 of the consecutively numbered lots in said city and being the lands conveyed to Randy F. Kemp by official record volume 2110, page 686 and official record volume 1063, page 6 and being more particularly described as follows:

Commencing at an iron pin found and accepted as marking the southeast corner of said Lot 457;

Thence, **North 86 degrees 53 minutes 23 seconds West, 60.00 feet** along the south line of said Lot 457 to an iron pin found in the southwest corner of a parcel conveyed to Christina Boyd by official record volume 1910, page 351;

Thence **North 02 degrees 43 minutes 07 seconds East, 23.59 feet** along the west line of said Boyd parcel to an iron pin set in a northeast corner of a parcel conveyed to Erica Blevins by official record volume 2274, page 710, said iron pin also being the **Place of Beginning** of the parcel described herein;

Thence, the following **FOUR** courses:

1. **North 86 degrees 53 minutes 23 seconds West, 35.62 feet** along the north line of said Blevins parcel to an iron pipe found in the southeast corner of a parcel conveyed to Erica Boor by official record volume 2733, page 180;
2. **North 02 degrees 43 minutes 07 seconds East, 36.41 feet** along the east line of said Boor parcel to an iron pin set in the northeast corner thereof, the north line of said Lot 457, also being on the south right of way line of Home Avenue-(40' R/W);
3. **South 86 degrees 53 minutes 23 seconds East, 35.62 feet** along the north line of said Lot 457, said south right of way line of Home Avenue, to an iron pin found in the northwest corner of the aforementioned Boyd parcel;
4. **South 02 degrees 43 minutes 07 seconds West, 36.41 feet** along the west line of said Boyd parcel to the **Place of Beginning** and containing 0.0298 of an acre (1296.85 square feet), more or less, and subject to all legal highways, easements, leases, servitudes, and use restrictions of record.

Bearings are to an assumed meridian and are used to express angles only.

Iron pins set are 5/8" rebar with plastic cap stamped "Ramsey S-8396".

According to a survey made in September, 2022 by Nathaniel B. Ramsey, Ohio Registered Professional Surveyor No. 8396.

Nathaniel B. Ramsey
Professional Surveyor No. 8396
For Ramsey Surveying
SM-5761_LEGAL.docx



NEW SURVEY
OF EXISTING PARCEL
RICHLAND COUNTY
TAX MAP OFFICE

EAK 10-24-22

INITIAL & DATE

OO-355