

NEW SURVEY
OF EXISTING PARCEL
RICHLAND COUNTY
TAX MAP OFFICE
EAK 10-24-22

INITIAL & DATE
00-354

- LEGEND**
- IRON PIPE FOUND
 - △ IRON PIN FOUND
 - IRON PIN SET-5/8" REBAR
SET WITH I.D. CAP STAMPED
"RAMSEY S-8396"

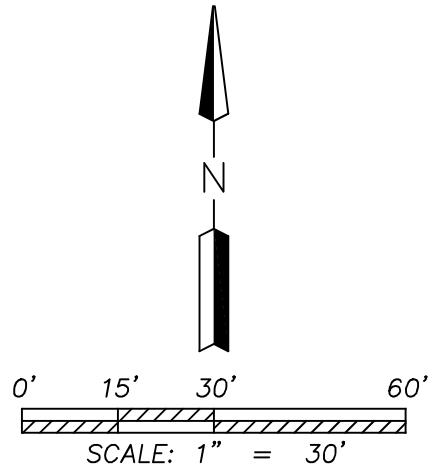

Distances shown hereon are expressed in feet and decimal parts thereof.

Bearings are to an assumed meridian and are used to express angles only.

CERTIFICATION: I hereby state that the foregoing survey was prepared from actual field measurements, in accordance with Chapter 4733-37, Ohio Administrative Code.

By: *Nathaniel B. Ramsey* 10/03/2022
Nathaniel B. Ramsey, P.S. #8396 Date
For Ramsey Surveying

RAMSEY SURVEYING Professional Land Surveying Services			
283 Eby Road Shiloh, Ohio 44878 TEL (419) 512-2596 FAX (419) 522-0399 EMAIL nramsey@ramsey-surveying.com			
SURVEY MADE FOR PROPERTY TRANSFER			
PART OF LOTS 53 & 54 IN WOOSTER HEIGHTS ALLOTMENT AS SHOWN ON PV. 14, PG. 11, MADISON TOWNSHIP, RICHLAND COUNTY, OHIO			
DRAWN HCC	CHECKED NBR	SCALE 1" = 30'	DATE 10/03/2022
JOB NO: SM-5765			SHEET 1 OF 1

October 3, 2022

LEGAL DESCRIPTION

Situated in the Township of Madison, County of Richland, State of Ohio, and being a part of Lot 53 and part of Lot 54, Wooster Heights Allotment, as shown on plat volume 14, page 11 and being the lands conveyed to Randy F. Kemp by official record volume 27, page 931 and being more particularly described as follows:

Beginning for the same at an iron pipe found and accepted as marking the southeast corner of said Lot 53 and being the intersection of the north right of way line of Bechtel Avenue-(60' R/W) and the west right of way line of Walker Avenue-(60' R/W);

Thence, the following **FOUR** courses:

1. **North 89 degrees 00 minutes 20 seconds West, 100.00 feet** along the south line of said Lot 53, said north right of way line of Bechtel Avenue, to an iron pin set in the southeast corner of a parcel conveyed to Donald Cricks by official record volume 2723, page 737;
2. **North 01 degree 13 minutes 11 seconds East, 100.00 feet** along the east line of said Cricks parcel to an iron pin set in the northeast corner thereof, also being on the south line of Lot 55;
3. **South 89 degrees 00 minutes 20 seconds East, 100.00 feet** along the south line of said Lot 55 to an iron pin set in the southeast corner thereof, also being on the aforementioned west right of way line of Walker Avenue, and being referenced by an iron pipe found South 56 degrees 10 minutes 18 seconds East, 1.84 feet therefrom;
4. **South 01 degree 13 minutes 11 seconds West, 100.00 feet** along the east line of the aforementioned Lot 54 and Lot 53, being said west right of way line of Walker Avenue, to the **Place of Beginning** and containing 0.2296 of an acre (9,999.94 sf), of which 0.1148 of an acre (4999.97 sf) is located within said Part Lot 53 and 0.1148 of an acre (4999.97 sf) is located within said Part Lot 54, more or less, and subject to all legal highways, easements, leases, servitudes, and use restrictions of record.

Bearings are to an assumed meridian and are used to express angles only.

Iron pins set are 5/8" rebar with plastic cap stamped "Ramsey S-8396".

According to a survey made in October, 2022 by Nathaniel B. Ramsey, Ohio Registered Professional Surveyor No. 8396.



Nathaniel B. Ramsey
Professional Surveyor No. 8396
For Ramsey Surveying
SM-5765_LEGAL.docx



NEW SURVEY
OF EXISTING PARCEL
RICHLAND COUNTY
TAX MAP OFFICE

EAK 10-24-22

INITIAL & DATE

00-354