

LINE	BEARING	DISTANCE
L-1	N 89°41'41" E	120.00'

** P.O.B. PARCEL "B"
NE CORNER, NW 1/4
OF SECTION 27

NEW SPLIT
RICHLAND COUNTY
TAX MAP OFFICE
EAK 10-3-22
INITIAL & DATE
NEW SURVEY
OF EXISTING PARCEL
RICHLAND COUNTY
TAX MAP OFFICE
EAK 10-3-22
INITIAL & DATE
OO-323

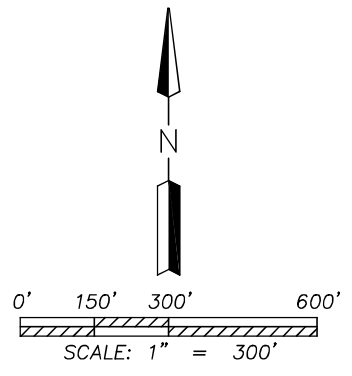

- LEGEND**
- IRON PIN/PIPE FOUND
 - △ RAILROAD SPIKE FOUND
 - IRON PIN SET-5/8" REBAR SET WITH I.D. CAP STAMPED "RAMSEY S-8396"

Distances shown hereon are expressed in feet and decimal parts thereof.

Bearings are to an assumed meridian and are used to express angles only.

CERTIFICATION: I hereby state that the foregoing survey was prepared from actual field measurements, in accordance with Chapter 4733-37, Ohio Administrative Code.

By: Nathaniel B. Ramsey, P.S. #8396 09/16/2022 Date
For Ramsey Surveying



RAMSEY SURVEYING
Professional Land Surveying Services
283 Eby Road
Shiloh, Ohio 44878
TEL (419) 512-2596 FAX (419) 522-0399
EMAIL nramsey@ramsey-surveying.com

SURVEY MADE FOR PROPERTY TRANSFER

PART OF THE NORTHWEST AND SOUTHWEST QUARTERS OF SECTION 27, JEFFERSON TOWNSHIP T-19 N, R-18 W RICHLAND COUNTY, OHIO

DRAWN NBR	CHECKED	SCALE 1" = 300'	DATE 09/16/2022
JOB NO: SM-5753		SHEET 1 OF 1	

LEGAL DESCRIPTION

PARCEL "A"

September 13, 2022

Situated in the Township of Jefferson, County of Richland, State of Ohio, and being a part of the Northwest Quarter of Section 27, Township 19-North, Range 18-West and being a portion of a parcel conveyed to Michael F. & Phyllis A. Patterson by official record volume 631, page 26 of the Richland County Recorder's records and being more particularly described as follows:

Commencing at an iron pin set marking the northeast corner of said Quarter, being in the centerline of Wagner Road-(T.H. 394)(60' R/W);

Thence, **South 89 degrees 41 minutes 41 seconds West, 120.00 feet** along the north line of said Quarter and said centerline to an iron pin set, the **Place of Beginning** for the parcel herein described;

Thence, the following **FOUR** courses:

1. **South 00 degrees 24 minutes 37 seconds East, 1037.11 feet** traversing said Patterson parcel to an iron pin set, and passing through an iron pin set for reference at 30.00 feet;
2. **South 89 degrees 41 minutes 41 seconds West, 1207.77 feet** traversing said Patterson parcel to an iron pin set on the east line of a parcel conveyed to Christine Mitchell by official record volume 2770, page 640;
3. **North 00 degrees 26 minutes 04 seconds West, 1037.11 feet** along the east line of said Mitchell parcel and the east line of a parcel conveyed to Judith A. Davis & Ralph W. Greer by official record volume 2665, page 644 to a railroad spike found in the northeast corner of said Greer parcel, passing through an iron pin found for reference at 1007.11 feet, and being on the north line of said Quarter, the centerline of Wagner Road;
4. **North 89 degrees 41 minutes 41 seconds East, 1208.20 feet** along the north line of said Quarter and said centerline to the **Place of Beginning**, containing 28.7605 acres, more or less, and subject to all legal highways, easements, leases, and use restrictions of record.

Bearings are to an assumed meridian and are used to express angles only.

Iron pins set are 5/8" rebar with plastic cap stamped "Ramsey-S-8396"

According to a survey made September 2022 by Nathaniel B. Ramsey, Ohio Registered Professional Surveyor No. 8396.

Nathaniel B. Ramsey
Professional Surveyor No. 8396
For Ramsey Surveying
SM-5753_Parcel A.docx



RAMSEY SURVEYING
Professional Land Surveying Services

283 Eby Road
Shiloh, Ohio 44878
TEL (419) 512-2596
FAX (419) 522-0399
EMAIL nramsey@ramsey-surveying.com

LEGAL DESCRIPTION

PARCEL "B"

September 13, 2022

Situated in the Township of Jefferson, County of Richland, State of Ohio, and being a part of the Northwest and Southwest Quarters of Section 27, Township 19-North, Range 18-West and being a portion of a parcel conveyed to Michael F. & Phyllis A. Patterson by official record volume 631, page 26 of the Richland County Recorder's records and being more particularly described as follows:

Beginning for the same at an iron pin set marking the northeast corner of said Northwest Quarter, being in the centerline of Wagner Road-(T.H. 394)(60' R/W);

Thence, the following **SEVEN** courses:

1. **South 00 degrees 24 minutes 37 seconds East, 2586.57 feet** along the east line of said Northwest Quarter to an iron pin set in the southeast corner thereof, and passing through an iron pin set for reference at 25.00 feet;
2. **South 00 degrees 47 minutes 45 seconds East, 874.50 feet** along the east line of said Southwest Quarter to an iron pin found in the northeast corner of a parcel conveyed to David C. Pamer & Mathias G. Pamer by official record volume 2915, page 312;
3. **South 89 degrees 05 minutes 22 seconds West, 1332.68 feet** along the north line of said Pamer parcel to an iron pin found in the southeast corner of a parcel conveyed to Carol E. Myers by official record volume 360, page 889;
4. **North 00 degrees 26 minutes 04 seconds West, 2438.01 feet** along the east line of said Myers parcel and the east line of a parcel conveyed to Christine Mitchell by official record volume 2770, page 640 to an iron pin set;
5. **North 89 degrees 41 minutes 41 seconds East, 1207.77 feet** traversing said Patterson parcel to an iron pin set;
6. **North 00 degrees 24 minutes 37 seconds West, 1037.11 feet** traversing said Patterson parcel to an iron pin set on the north line of said Northwest Quarter, said centerline of Wagner Road, and passing through an iron pin set for reference at 1007.11 feet;

7. **North 89 degrees 41 minutes 41 seconds East, 120.00 feet** along the north line of said Quarter and said centerline to the **Place of Beginning**, containing a total of 76.9876 acres, more or less, of which 50.3119 acres are located within said Northwest Quarter and 26.6757 acres are located within said Southwest Quarter, and subject to all legal highways, easements, leases, and use restrictions of record.

Bearings are to an assumed meridian and are used to express angles only.

Iron pins set are 5/8" rebar with plastic cap stamped "Ramsey-S-8396"

According to a survey made September 2022 by Nathaniel B. Ramsey, Ohio Registered Professional Surveyor No. 8396.

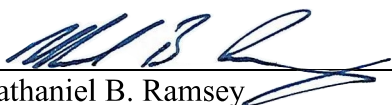
Nathaniel B. Ramsey
Professional Surveyor No. 8396
For Ramsey Surveying
SM-5753_Parcel B.docx



NEW SURVEY
OF EXISTING PARCEL
RICHLAND COUNTY
TAX MAP OFFICE

EAK 10-3-22

INITIAL & DATE

00-323