

NEW SURVEY
 OF EXISTING PARCEL
 RICHLAND COUNTY
 TAX MAP OFFICE
EAK 9-2-22
 INITIAL DATE

00-288

LINE	BEARING	DISTANCE
L1	N 01°04'03" W	19.60'
L2	S 01°04'03" E	19.03'

LEGEND

- IRON PIN FOUND
- △ IRON PIPE FOUND
- IRON PIN SET-5/8" REBAR
SET WITH I.D. CAP STAMPED
"RAMSEY S-8396"

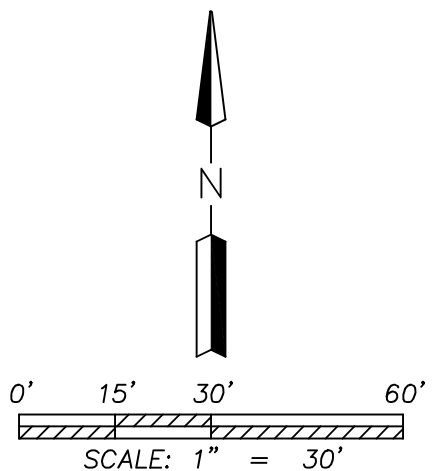

Distances shown hereon are expressed in feet and decimal parts thereof.

Bearings are to an assumed meridian and are used to express angles only.

CERTIFICATION: I hereby state that the foregoing survey was prepared from actual field measurements, in accordance with Chapter 4733-37, Ohio Administrative Code.

By: Nathaniel B. Ramsey, P.S. #8396 08/16/2022
 For Ramsey Surveying Date

RAMSEY SURVEYING
 Professional Land Surveying Services
 283 Eby Road
 Shiloh, Ohio 44878
 TEL (419) 512-2596 FAX (419) 522-0399
 EMAIL nramsey@ramsey-surveying.com

**SURVEY MADE AT THE REQUEST OF
 TAMI COOK**

**PART OF LOTS 19182, 19183 & 19187
 IN THE CITY OF MANSFIELD
 MADISON TOWNSHIP
 RICHLAND COUNTY, OHIO**

DRAWN HCG	CHECKED NBR	SCALE 1" = 30'	DATE 08/16/2022
JOB NO: SM-5736			SHEET 1 OF 1

RAMSEY SURVEYING
Professional Land Surveying Services

283 Eby Road
Shiloh, Ohio 44878
TEL (419) 512-2596
FAX (419) 522-0399
EMAIL nramsey@ramsey-surveying.com

September 2, 2022

LEGAL DESCRIPTION

Situated in the City of Mansfield, County of Richland, State of Ohio, being parts of Lots 19182, 19183 and 19187 of the consecutively numbered lots in said city and being the lands conveyed to The Gladys N. Cook Revocable Living Trust by official record volume 1962, page 793 and official record volume 2466, page 667 and being more particularly described as follows:

Beginning for the same at an iron pin set in the southeast corner of said Lot 19182, also being the southwest corner of a parcel conveyed to William N. Spognardi Jr. by official record volume 882, page 802;

Thence with the following **EIGHT** courses:

1. **South 88 degrees 47 minutes 33 seconds West, 100.00 feet** along the south line of said Lot 19182 and Lot 19187 to a point in the southwest corner of said Lot 19187, being referenced by an iron pin found North 64 degrees 33 minutes 54 seconds West, 0.33 feet therefrom, passing through an iron pipe found at 50.00 feet;
2. **North 01 degree 04 minutes 03 seconds West, 100.00 feet** along the west line of said Lot 19187 to an iron pin set in the southwest corner of a parcel conveyed to Ted Ferguson by official record volume 274, page 977;
3. **North 88 degrees 47 minutes 33 seconds East, 50.00 feet** along the south line of said Ferguson parcel to an iron pin set in the southeast corner thereof, and being on the west line of aforementioned Lot 19182;
4. **North 01 degree 04 minutes 03 seconds West, 19.60 feet** along said west line of Lot 19182, the east line of said Ferguson parcel to an iron pin set in the northeast corner thereof;
5. **North 89 degrees 07 minutes 05 seconds East, 100.00 feet** traversing aforementioned Lot 19182 and Lot 19183 to an iron pin set on the east line of said Lot 19183;
6. **South 01 degree 04 minutes 03 seconds East, 19.03 feet** along the east line of said Lot 19183 to an iron pin set in an interior corner of the aforementioned Spognardi Jr. parcel;
7. **South 88 degrees 47 minutes 33 seconds West, 50.00 feet** along a north line of said Spognardi Jr. parcel to an iron pin set in a northwest corner thereof, being on the east line of aforementioned Lot 19182;

8. **South 01 degree 04 minutes 03 seconds East, 100.00 feet** along the east line of said Lot 19182 and the west line of said Spognardi parcel to the **Place of Beginning** and containing a total of 0.2739 of an acre (11,931.08 square feet), of which 0.1148 of an acre is located within Part Lot 19187, 0.1371 of an acre is located within Part Lot 19182 and 0.0220 of an acre is located within Part Lot 19183 more or less, and subject to all legal highways, easements, leases, servitudes, and use restrictions of record.

Iron pins set are 5/8" diameter rebar with plastic cap stamped "Ramsey S-8396".

Bearings are to an assumed meridian and are used to express angles only.

According to a survey made in August, 2022 by Nathaniel B. Ramsey, Ohio Registered Professional Surveyor No. 8396.



Nathaniel B. Ramsey
Professional Surveyor No. 8396
For Ramsey Surveying
SM-5736_LEGAL

NEW SURVEY
OF EXISTING PARCEL
RICHLAND COUNTY
TAX MAP OFFICE

EAK 9-2-22

INITIAL DATE

00-288