

SURVEY FOR
PROPERTY TRANSFER
0.5990 ACRES
26,090.75 SQ. FT.

BOARD OF EDUCATION OF
PLYMOUTH
SHILOH LOCAL SCHOOL DISTRICT
ORV. 1830, PG. 783

MELISSA E. MULVANE & ARLENE L. MURRAY
ORV. 2639, PG. 617

NEW SPLIT
RICHLAND COUNTY
TAX MAP OFFICE
EAK **5-9-22**
INITIAL DATE
00-142

Zoning Wayne B. Figgitt



- LEGEND**
- IRON PIN/PIPE FOUND
 - △ RAILROAD SPIKE FOUND
 - IRON PIN SET-5/8" REBAR SET WITH I.D. CAP STAMPED "RAMSEY S-8396"

Distances shown hereon are expressed in feet and decimal parts thereof.

Bearings are to an assumed meridian and are used to express angles only.

CERTIFICATION: I hereby state that the foregoing survey was prepared from actual field measurements, in accordance with Chapter 4733-37, Ohio Administrative Code.

By: *Nathaniel B. Ramsey* 04/07/2022
Nathaniel B. Ramsey, P.S. #8396 Date
For Ramsey Surveying

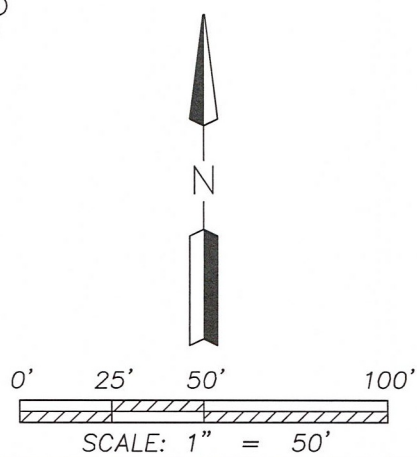

RAMSEY SURVEYING
Professional Land Surveying Services
283 Eby Road
Shiloh, Ohio 44878
TEL (419) 512-2596 FAX (419) 522-0399
EMAIL nramsey@ramsey-surveying.com

SURVEY MADE FOR PROPERTY TRANSFER

**SITUATED IN THE VILLAGE OF PLYMOUTH,
BEING A PART OF THE NORTHEAST QUARTER
OF SECTION 5, PLYMOUTH TOWNSHIP
T-23 N, R-19 W
RICHLAND COUNTY, OHIO**

| | | | |
|-----------------|----------------|-------------------|--------------------|
| DRAWN HCC | CHECKED NSR | SCALE 1" = 50' | DATE 04/07/2022 |
| JOB NO: SM-5679 | | SHEET 1 OF 1 | |

RAMSEY SURVEYING
Professional Land Surveying Services

283 Eby Road
Shiloh, Ohio 44878
TEL (419) 512-2596
FAX (419) 522-0399
EMAIL nramsey@ramsey-surveying.com

LEGAL DESCRIPTION

April 7, 2022

Situated in the Village of Plymouth, County of Richland, State of Ohio, and being a part of the Northeast Quarter of Section 5, Township 23-North, Range 19-West and being a portion of the lands conveyed to Board of Education of Plymouth Shiloh Local School District by official record volume 1830, page 783 of the Richland County Recorder's records and being more particularly described as follows:

Commencing at a railroad spike found at the intersection of the east line of said Quarter with the centerline of State Route 603-(60' R/W);

Thence, **North 53 degrees 24 minutes 55 seconds West, 460.81 feet** along said centerline of State Route 603 to a point in the northwest corner of a parcel conveyed to Melissa E. Mulvane and Arlene L. Murray by official record volume 2639, page 617, being the **Place of Beginning** of the parcel herein described;

Thence, the following **FIVE** courses:

1. **South 01 degree 58 minutes 54 seconds West, 210.00 feet** along the west line of said Mulvane/Murray parcel to an iron pin set, passing through an iron pin set for reference at 36.45 feet;
2. **North 52 degrees 45 minutes 31 seconds West, 215.00 feet** traversing aforementioned Board of Education parcel to an iron pin set;
3. **North 38 degrees 30 minutes 59 seconds East, 170.00 feet** traversing said Board of Education parcel to a point on the aforementioned centerline of State Route 603, passing through an iron pin set for reference at 139.97 feet;
4. **South 54 degrees 11 minutes 26 seconds East, 35.83 feet** along said centerline of State Route 603 to a point of deflection referenced by an iron pin found North 00 degrees 39 minutes 45 seconds West, 38.11 feet therefrom;

5. **South 53 degrees 24 minutes 55 seconds East, 54.17 feet** continuing along said centerline of State Route 603 to the **Place of Beginning** and containing 0.5990 of an acre (26,090.75 Sq. Ft.), more or less, and subject to all legal highways, easements, leases, and use restrictions of record.

Bearings are to an assumed meridian and are used to express angles only.

Iron pins set are 5/8" rebar with plastic cap stamped "Ramsey S-8396"

According to a survey made April 2022 by Nathaniel B. Ramsey, Ohio Registered Professional Surveyor No. 8396.

Nathaniel B. Ramsey
Professional Surveyor No. 8396
For Ramsey Surveying
SM-5679 LEGAL



NEW SPLIT
RICHLAND COUNTY
TAX MAP OFFICE
EAK 5-9-22
INITIAL DATE
00-142