

STEPHEN N. JR. & DOROTHY NEWSWANGER
ORV. 2833, PG. 183

CHARLES R. & MARILYN PENNELL &
RICHARD L. & BARBARA J. ADAMS, TRUSTEE
ORV. 2950, PG. 515 & ORV. 2965, PG. 538

STEPHEN Z. & MABEL Z. NEWSWANGER
ORV. 1642, PG. 859

**SURVEY FOR
PROPERTY TRANSFER
7.1790 ACRES**

(4.0468 Ac.)

(3.1322 Ac.)

R=2022.20'
A=253.16'
Δ=7°10'22"
CH. BRG=N 47°54'09" W
CH. DIST=252.99'

LINE	BEARING	DISTANCE
L1	N 88°27'19" E	111.59'
L2	S 01°32'41" E	92.97'
L3	N 44°18'58" W	108.85'

NEW SPLIT	NEW SURVEY
RICHLAND COUNTY	OF EXISTING PARCEL
TAX MAP OFFICE	RICHLAND COUNTY
EAK	EAK
4-11-22	4-11-22
INITIAL	DATE
INITIAL	DATE

00-101

LEGEND

- ⊗ R/W MONUMENT FOUND
- IRON PIN/PIPE FOUND
- △ MAGNAIL SPIKE FOUND
- ✕ 2" MAGNAIL SPIKE SET
- IRON PIN SET-5/8" REBAR SET WITH I.D. CAP STAMPED "RAMSEY S-8396"

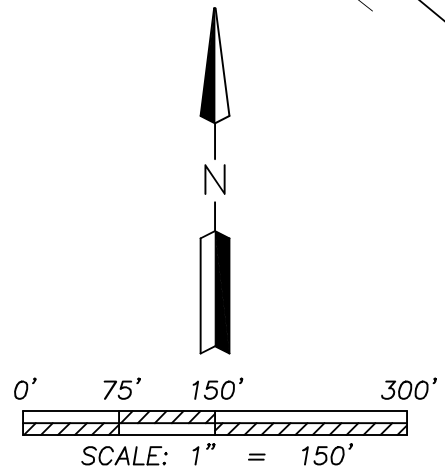

Distances shown hereon are expressed in feet and decimal parts thereof.

Bearings are to an assumed meridian and are used to express angles only.

CERTIFICATION: I hereby state that the foregoing survey was prepared from actual field measurements, in accordance with Chapter 4733-37, Ohio Administrative Code.

By: Nathaniel B. Ramsey, P.S. #8396 Date: 03/26/2022
For Ramsey Surveying

RAMSEY SURVEYING
Professional Land Surveying Services

283 Eby Road
Shiloh, Ohio 44878
TEL (419) 512-2596 FAX (419) 522-0399
EMAIL nramsey@ramsey-surveying.com

SURVEY MADE FOR PROPERTY TRANSFER

PART OF THE SE QUARTER OF SECTION 11 & PART OF THE SW QUARTER OF SECTION 12, CASS TOWNSHIP T-23 N, R-19 W RICHLAND COUNTY, OHIO

DRAWN HCG	CHECKED NBR	SCALE 1" = 150'	DATE 03/26/2022
JOB NO: SM-5393			SHEET 1 OF 1

RAMSEY SURVEYING
Professional Land Surveying Services

283 Eby Road
Shiloh, Ohio 44878
TEL (419) 512-2596
FAX (419) 522-0399
EMAIL nramsey@ramsey-surveying.com

LEGAL DESCRIPTION

March 26, 2022

Situated in the Township of Cass, County of Richland, State of Ohio and being a part of the Southeast Quarter of Section 11, a part of the Southwest Quarter of Section 12, Township 23 North, Range-19 West, and being a portion of the lands conveyed to Stephen N. Jr. and Dorothy Newswanger by official record volume 2833, page 183 of the Richland County Recorder's records and being more particularly described as follows:

Commencing at a stone found and accepted as marking the northeast corner of said Southeast Quarter, said stone also marking the northwest corner of a parcel conveyed to Charles R. & Marilyn Pennell by official record volume 2965, page 538 and Richard L. and Barbara J. Adams, trustee by official record volume 2950, page 515;

Thence **South 01 degree 32 minutes 41 seconds East, 1590.32 feet** along the east line of said Southeast Quarter, the west line of said Pennell & Adams' parcel to an iron pin set marking the **Place of Beginning** of the parcel herein described;

Thence, the following **TEN** courses:

1. **South 01 degree 32 minutes 41 seconds East, 227.72 feet** continuing along the east line of said Southeast Quarter and the west line of said Pennell & Adams' parcel to an iron pipe found in the southwest corner of said Pennell & Adams' parcel;
2. **North 88 degrees 56 minutes 24 seconds East, 210.00 feet** along the south line of said Pennell & Adams' parcel to an iron pin found in the northwest corner of a parcel in the name of Stephen Z. and Mabel Z. Newswanger by official record volume 1642, page 859;
3. **South 01 degree 32 minutes 45 seconds East, 457.33 feet** along a west line of said Stephen Z. Newswanger parcel to an iron pin found in a westerly corner thereof;
4. **South 31 degrees 58 minutes 49 seconds East, 237.77 feet** along a southwesterly line of said Stephen Z. Newswanger parcel to an iron pin found in an interior corner thereof;
5. **South 01 degree 32 minutes 41 seconds East, 92.97 feet** along a west line of said Stephen Z. Newswanger parcel to a point on the centerline of State Route 603-(60' R/W), and passing through an iron pin found for reference at 52.97 feet;

6. **North 51 degrees 29 minutes 20 seconds West, 666.96 feet** along the centerline of State Route 603 to a point of curvature, said point being referenced by a concrete R/W monument found North 38 degrees 30 minutes 40 seconds East, 30.00 feet therefrom;
7. Along a curve to the right with a **radius of 2022.20 feet, with an arc length of 253.16 feet, with a delta angle of 07 degrees 10 minutes 22 seconds, a chord bearing North 47 degrees 54 minutes 09 seconds West, and a chord length of 252.99 feet** continuing along said centerline of State Route 603 to a Magnail spike found marking a point of tangency;
8. **North 44 degrees 18 minutes 58 seconds West, 108.85 feet** continuing along said centerline of State Route 603 to a 2" Magnail spike set;
9. **North 45 degrees 41 minute 02 seconds East, 443.37 feet** traversing aforementioned Stephen N. Jr. and Dorothy Newswanger parcel to an iron pin set, passing through an iron pin set for reference at 30.00 feet;
10. **North 88 degrees 27 minutes 19 seconds East, 111.59 feet** traversing said Stephen N. Newswanger parcel to the **Place of Beginning**, containing a total of 7.1790 acres, of which, 4.0468 acres are located in said Southeast Quarter of Section 11, and 3.1322 acres are located in said Southwest Quarter of Section 12, and subject to all legal highways and easements, leases, and use restrictions of record.

Bearings are to an assumed meridian and are used to express angles only.

Iron pins set are 5/8" rebar with plastic cap stamped "Ramsey S-8396".

According to a survey made March 2022 by Nathaniel B. Ramsey, Ohio Registered Professional Surveyor No. 8396.

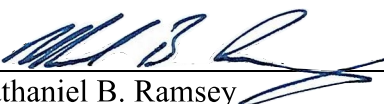

 Nathaniel B. Ramsey
 Professional Surveyor No. 8396
 For Ramsey Surveying
 SM-5393 LEGAL 2022



NEW SPLIT RICHLAND COUNTY TAX MAP OFFICE <u>EAK</u> <u>4-11-22</u> INITIAL DATE	NEW SURVEY OF EXISTING PARCEL RICHLAND COUNTY TAX MAP OFFICE <u>EAK</u> <u>4-11-22</u> INITIAL DATE
<u>00-101</u>	