

CHARLES G. METCALF AND
BRENDA S. METCALF
ORV. 1192, PAGE 430

N 89°46'16" E 348.48'

REF=30.00'

* Approved Franklin Township zoning

4-27-20

C. P. R. + L.

2.000 ACRES

S 00°13'44" E 250.00'

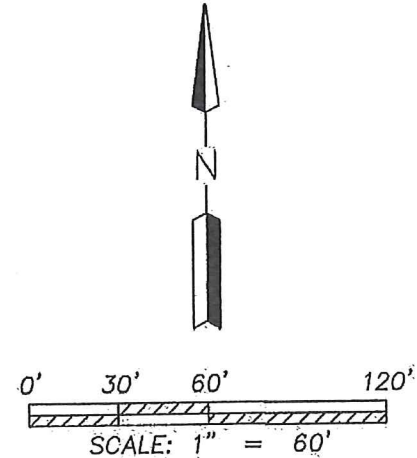

Distances shown hereon are expressed in feet and decimal parts thereof.

Bearings are to an assumed meridian and are used to express angles only.

CERTIFICATION: I hereby state that the foregoing survey was prepared from actual field measurements, in accordance with Chapter 4733-37, Ohio Administrative Code.

By: Nathaniel B. Ramsey, P.S. #8396 04/22/2020
For Ramsey Surveying Date

NEW SPLIT
RICHLAND COUNTY
TAX MAP OFFICE

FAK 4-28-20
INITIAL DATE

Approved according
to R.C. 711.131

Eldred G. Kuhn 4-28-20
Sign Date

MM-114

FRANK ROAD - (T.H. 450) (30' R/W)

N 00°13'44" W 250.00'

P.O.B.

REF=30.00'

S 89°46'16" W 348.48'

The E. Line NW 1/4
N 00°13'44" W 322.84'

N 08°37'54" W
5.26'

The SW Corner
of the NE 1/4
of Section 27



LEGEND

- IRON PIN FOUND
- △ RAILROAD SPIKE FOUND
- ✕ MAGNAIL SPIKE SET
- IRON PIN SET-5/8" REBAR SET WITH I.D. CAP STAMPED "RAMSEY S-8396"

RAMSEY SURVEYING
Professional Land Surveying Services

283 Eby Road
Shiloh, Ohio 41878
TEL (419) 512-2596 FAX (419) 522-0399
EMAIL nramsey@ramsey-surveying.com

SURVEY FOR PROPERTY TRANSFER

**PART OF THE NORTHEAST QUARTER
OF SECTION 27, FRANKLIN TOWNSHIP
T-22 N, R-18 W
RICHLAND COUNTY, OHIO**

DRAWN HR	CHECKED HR	SCALE 1" = 60'	DATE 04/10/2020
JOB NO: SM-5401		SHEET 1 OF 1	

RAMSEY SURVEYING
Professional Land Surveying Services

283 Eby Road
Shiloh, Ohio 44878
TEL (419) 512-2596
FAX (419) 522-0599
EMAIL: nramsey@ramsey-surveying.com

LEGAL DESCRIPTION

Situated in the Township of Franklin, County of Richland, State of Ohio and being part of the Northeast Quarter of Section 27, Township 22 North, Range 18 West, and being a portion of a parcel conveyed to Charles G. Metcalf and Brenda S. Metcalf by official record volume 1192, page 430 of the Richland County Recorder's records and being more particularly described as follows:

Commencing at a point in the southwest corner of said Northeast Quarter, being referenced by an iron pin found North 08 degrees 37 minutes 54 seconds West, 5.26 feet from said point;

Thence, North 00 degrees 13 minutes 44 seconds West, 322.84 feet along the west line of said quarter, the same being the centerline of Frank Road-(T.H. 450)(30') to a Magnail spike set, and being the Place of Beginning of the parcel herein described;

Thence, the following FOUR courses:

1. North 00 degrees 13 minutes 44 seconds West, 250.00 feet continuing along the west line of said quarter and said centerline to a Magnail spike set;
2. North 89 degrees 46 minutes 16 seconds East, 348.48 feet to an iron pin set, and passing through an iron pin set for reference at 30.00 feet;
3. South 00 degrees 13 minutes 44 seconds East, 250.00 feet to an iron pin set;
4. South 89 degrees 46 minutes 16 seconds West, 348.48 feet to the Place of Beginning, passing through an iron pin set for reference at 318.48 feet, and containing 2.000 acres, more or less and subject to all legal highway, easements, leases, and use restrictions of record.

Bearings are based on an assumed meridian and are used to express angles only.

Iron pins set are 5/8" rebar with cap stamped "Ramsey S-8396"

According to a survey made in April 2020 by Nathaniel B. Ramsey, Ohio Registered Professional Surveyor No. 8396.

Nathaniel B. Ramsey

Professional Surveyor No. 8396
For Ramsey Surveying
SM-5401.docx



Approved Franklin Twp
Zoning
4-27-20
S.P.R.J.L.

NEW SPLIT
RICHLAND COUNTY
TAX MAP OFFICE

FAK 4-28-20
INITIAL DATE
MM-114

Approved according
to R.C. 711.131

 Sign
Date 4-28-20



Environmental Division
555 Lexington Ave.
Mansfield, OH 44907
 (419)774-4520 phone
 (419)774-0845 fax

Lot Split Application

Review by Richland Public Health (RPH) is required for any lot split that does not have an associated sanitary sewer tap, a sewage treatment system that will remain on lot, and/or where potential buildable lots may be created with no access to sanitary sewer system.

Richland Public Health will assess existing sewage treatment system(s) to ensure proper function, establish that space remains on the lot(s) for replacement of existing sewage treatment(s), assign required area for installation of sewage treatment system(s) on new lots, and determine that any split does not encroach on required isolation distances.

Applicant Information

Name Matt & Mandy Metcalf		Date 4/14/2020	
Mailing Address 2249 Ranchwood Dr.		City Mansfield	State OH
Email mcmetcalf@richlandcountyoh.us		Zip 44903	Phone 419-961-2934

Site Information

Site Address 3120 Frank Rd.			
City Mansfield	State OH	Zip 44903	Township Franklin
Parcel #(s) 0114012116001		Total Acreage (Before Lot Splits) 20.465	

Acreage Per Lot(s):

Lot 1: 18.465 Existing Home (check if yes) Combining to Another Lot?

Lot 2: 2.00

Lot 3:

Lot 4:

Lot 5:

All newly created lots under five (5) acres will be required to have a soil evaluation conducted by an approved Soil Evaluator.

All newly created lots that are 5 acres or greater, will not be required to have a soil evaluation conducted by an approved Soil Evaluator unless a building location has been determined on the new lot.

A septic permit will not be issued for a lot until a soil evaluation has been conducted by an approved Soil Evaluator.

As required by Ohio Administrative Code (OAC) 3701-29-08, the following information must be submitted with this application prior to review:

- (1) Soil Evaluation Report for each lot in accordance with OAC 3701-29-07.
- (2) Staked or marked locations of proposed lot corners/property lines.
- (3) A survey prepared for each lot by a Registered Surveyor

Yes
 Yes
 Yes

✓ #109
Rec# 589 L.L.H
4-16-20

APR 16 2020

4-16-20
paid on
franklin
metcalf

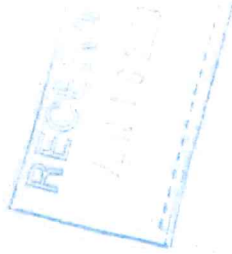

Yes

(4) Scaled site drawing including: (a) acreage of each proposed lot and land area; (b) proposed lot lines with detail of site conditions including vegetation and drainage; (c) site information including easements, utilities, structures, wells, foundations, roads, drainage features, water bodies. (Include: future buildings, landscaping, pools, etc)

Yes

(5) Identification of one or more sewage treatment system type(s) that might be feasible for each lot.

Please submit this completed form, the above required documents and payment of \$75.00 per each new lot either by mail or in person to: Richland Public Health, 555 Lexington Avenue, Mansfield, OH 44907 (Checks payable to: Richland Public Health).

This evaluation does not indicate specific sewage treatment system type(s) to be installed on the lot(s). A site review for permit must be approved by RPH to determine exact specifications, type, and size of system. This evaluation is not a guarantee of system approval or type and applies to only those site conditions known at the time of inspection and documents submitted for review. The review is limited to the site conditions at time of inspection and documents submitted for review.

Applicant Signature <i>Mary Minton</i>	Date <i>4/13/2020</i>
---	--------------------------

Mary Minton

OFFICE USE ONLY

Final Lot Split Consideration:

<input checked="" type="checkbox"/> Approved	Sanitarian Signature <i>[Signature]</i>	Date of Approval <i>04/17/2020</i>
<input type="checkbox"/> Disapproved	Sanitarian Signature <i>R.S.</i>	Date of Disapproval
<input type="checkbox"/> Exempt	Sanitarian Signature	Date of Exempt Status

Comments:

Fee Paid	
Date Paid	
Receipt #	
Recorded By	
Date Recorded	

APR 16 2020

Updated 09/11/2019