

NEW SURVEY  
 OF EXISTING PARCEL  
 RICHLAND COUNTY  
 TAX MAP OFFICE  
**EAK 2-20-24**  
 INITIAL & DATE  
**QQ-51**

TRACY STREET-(60' R/W)  
 N 00°56'09" W 119.76'

PARNELL DRIVE-(16' R/W)  
 S 00°51'37" E 119.76'

N 89°06'48" E 184.30'

0.2546 AC.  
 11091.47 Sq. Ft.

**SURVEY FOR TRANSFER**  
**0.5064 AC.**  
**(22061.62 SQ. FT.)**  
**TOTAL**

LARRY MADDEN AND SHERRY MADDEN  
 ORV. 2208, PG. 67

0.2518 AC.  
 10970.15 Sq. Ft.

S 89°06'48" W 184.14'

N 81°55'42" E 1.46'

P.O.B.

N 00°56'09" W  
 180.15'

McPHERSON ST.-(60' R/W)

LEGEND

- IRON PIPE FOUND
- ⊗ IRON PIN FOUND
- IRON PIN SET-5/8" REBAR  
 SET WITH I.D. CAP STAMPED  
 "RAMSEY S-8396"

Distances shown hereon are expressed in feet and decimal parts thereof.

Bearings are to an assumed meridian and are used to express angles only.

CERTIFICATION: I hereby state that the foregoing survey was prepared from actual field measurements, in accordance with Chapter 4733-37, Ohio Administrative Code.

By:  02/09/2024  
 Nathaniel B. Ramsey, P.S. #8396 Date  
 For Ramsey Surveying

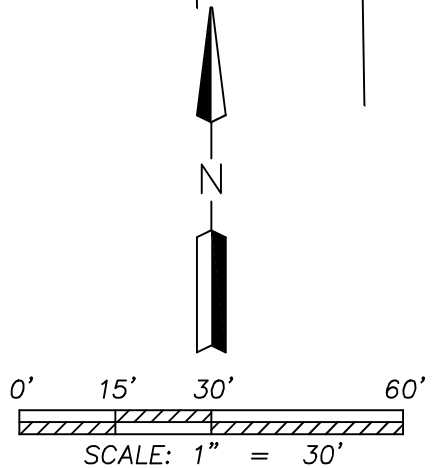

**RAMSEY SURVEYING**  
 Professional Land Surveying Services

283 Eby Road  
 Shiloh, Ohio 44878  
 TEL (419) 512-2596 FAX (419) 522-0399  
 EMAIL nramsey@ramsey-surveying.com

**SURVEY MADE FOR PROPERTY TRANSFER**

**PART OF OUTLOT 249,  
 PLAT BOOK 4, PAGE 27  
 CITY OF MANSFIELD,  
 RICHLAND COUNTY, OHIO**

DRAWN NBR	CHECKED NBR	SCALE 1" = 30'	DATE 02/09/2024
JOB NO: SM-5934			SHEET 1 OF 1

**RAMSEY SURVEYING**  
*Professional Land Surveying Services*

283 Eby Road  
Shiloh, Ohio 44878  
TEL (419) 512-2596  
FAX (419) 522-0399  
EMAIL nramsey@ramsey-surveying.com

**LEGAL DESCRIPTION**

February 9, 2024

**Situated** in the State of Ohio, County of Richland, City of Mansfield; being a part of Out Lot 249 as recorded in plat book 4, page 27, being the lands conveyed to Larry Madden and Sherry Madden by official record volume 2208, page 67 of the Richland County Recorder's records, and being more particularly described as follows:

**Commencing** at an iron pipe found and accepted as marking the southwest corner of Out Lot 249, also marking the intersection of the north existing right of way line of McPherson Street-(60' R/W) with the east existing right of way line of Tracy Street-(60' R/W);

Thence, **North 00 degrees 56 minutes 09 seconds West, 180.15 feet** along the west line of said Out Lot 249, said east line of Tracy Street, to a point referenced by an iron pin found North 81 degrees 55 minutes 42 seconds East, 1.46 feet therefrom, and being the **Place of Beginning** of the parcel herein described:

Thence, the following **FOUR** Courses:

1. **North 00 degrees 56 minutes 09 seconds West, 119.76 feet** continuing along the west line of Out Lot 249, the east line of Tracy Street, to an iron pipe found;
2. **North 89 degrees 06 minutes 48 seconds East, 184.30 feet**, traversing said Out Lot 249, to an iron pipe found on the east line thereof, also being the west existing right of way line of Parnell Drive-(16' R/W);
3. **South 00 degrees 51 minutes 37 seconds East, 119.76 feet** along said east line of Out Lot 249, said west line of Parnell Drive, to an iron pin set;
4. **South 89 degrees 06 minutes 48 seconds West, 184.14 feet**, traversing said Out Lot 249, to the **Place of Beginning**, and containing a total of 0.5064 of an acre (22061.62 Sq. Ft.), more or less, and subject to all legal highways, easements, leases, and use restrictions of record.

Bearings are based on an assumed meridian and are used to express angles only.

Iron pins set are 5/8" rebar with I.D. cap stamped "Ramsey S-8396"

According to a survey made in February 2024 by Nathaniel B. Ramsey, Ohio Registered Professional Surveyor No. 8396.

NEW SURVEY  
OF EXISTING PARCEL  
RICHLAND COUNTY  
TAX MAP OFFICE  
**EAK 2-20-24**

INITIAL & DATE  
**QQ-51**

  
Nathaniel B. Ramsey  
Professional Surveyor No. 8396  
For Ramsey Surveying  
SM-5934 legal.docx

