

- LEGEND**
- IRON PIN/PIPE FOUND
 - IRON PIN SET-5/8" REBAR SET WITH I.D. CAP STAMPED "RAMSEY S-8396"

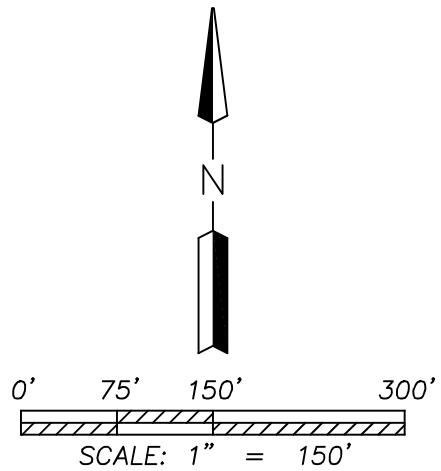

Distances shown hereon are expressed in feet and decimal parts thereof.

Bearings are to an assumed meridian and are used to express angles only.

CERTIFICATION: I hereby state that the foregoing survey was prepared from actual field measurements, in accordance with Chapter 4733-37, Ohio Administrative Code.

By: Nathaniel B. Ramsey 04/14/2023
 Nathaniel B. Ramsey, P.S. #8396 Date
 For Ramsey Surveying

RAMSEY SURVEYING
 Professional Land Surveying Services

283 Eby Road
 Shiloh, Ohio 44878
 TEL (419) 512-2596 FAX (419) 522-0399
 EMAIL nramsey@ramsey-surveying.com

SURVEY MADE AT THE REQUEST OF
ELMER SENSENIG

BEING A PART OF THE NORTHWEST QUARTER
OF SECTION 2, BUTLER TOWNSHIP,
T-23 N, R-18 W,
RICHLAND COUNTY, OHIO

DRAWN NBR	CHECKED NBR	SCALE 1" = 150'	DATE 04/14/2023
SM-5076_2023	JOB NO: SM-5076	SHEET 1 OF 1	

LEGAL DESCRIPTION

April 14, 2023

Situated in the Township of Butler, County of Richland, State of Ohio, and being a part of the Northwest Quarter of Section 2, Township 23-North, Range 18-West and being a portion of lands conveyed to Elmer B. Sensenig and Ruth Ann Sensenig by official record volume 1607, page 874 and official record volume 2179, page 283 of the Richland County Recorder's records and being more particularly described as follows:

Beginning for the same at a point at the intersection of the south line of said Northwest Quarter with the centerline of State Route 13-(60' R/W), and being referenced by an iron pipe found South 89 degrees 24 minutes 55 seconds West, 25.38 feet therefrom;

Thence, the following **FIVE** courses:

1. **North 12 degrees 33 minutes 47 seconds East, 770.60 feet** along said centerline of State Route 13 to a point;
2. **South 87 degrees 47 minutes 56 seconds East, 307.57 feet** to an iron pin set, and passing through an iron pin set for reference at 30.50 feet;
3. **South 60 degrees 14 minutes 42 seconds East, 209.89 feet** to an iron pin set;
4. **South 00 degrees 35 minutes 05 seconds East, 629.43 feet** to an iron pin set on the aforementioned south line of said Northwest Quarter;
5. **South 89 degrees 24 minutes 55 seconds West, 663.63 feet** along said south line to the **Place of Beginning**, passing through an iron pin set for reference at 632.82 feet, and containing a total of 9.5871 acres, more or less, and subject to all legal highways, easements, leases, and use restrictions of record.

Bearings are to an assumed meridian and are used to express angles only.

Iron pins set are 5/8" rebar with plastic cap stamped "Ramsey S-8396"

According to a survey made April 2023 by Nathaniel B. Ramsey, Ohio Registered Professional Surveyor No. 8396.

Nathaniel B. Ramsey
Professional Surveyor No. 8396
For Ramsey Surveying
SM-5076_2023.docx

