

NEIL BELCHER AND GLENDA BELCHER  
ORV. 2732, PG. 733

**REFERENCE DOCUMENTS:**

- SURVEY FOR ALBERT POTH DATED NOV. 1947
- SURVEY H-447
- SURVEY V-283
- SURVEY DD-55
- SURVEY KK-211
- SURVEY KK-339
- DV. 68, PG. 426
- DV. 68, PG. 429
- DV. 354, PG. 557
- HISTORICAL TAXMAPS, & 1960, 1997, 2019 & 2021 AERIAL IMAGERY

**LEGEND**

- IRON PIN/PIPE FOUND
- △ MAGNAIL SPIKE FOUND
- IRON PIN SET-5/8" REBAR SET WITH I.D. CAP STAMPED "RAMSEY S-8396"
- O. - OBSERVED
- D. - DEEDED
- x — EX. FENCE & OCCUPATION

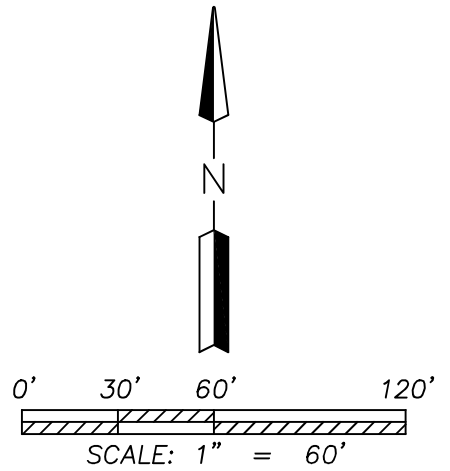

NEW SURVEY  
OF EXISTING PARCEL  
RICHLAND COUNTY  
TAX MAP OFFICE  
**EAK 9-29-23**  
INITIAL & DATE  
**PP-273**

Distances shown hereon are expressed in feet and decimal parts thereof.

Bearings are to an assumed meridian and are used to express angles only.

CERTIFICATION: I hereby state that the foregoing survey was prepared from actual field measurements, in accordance with Chapter 4733-37, Ohio Administrative Code.

By: *Nathaniel B. Ramsey* 09/27/2023  
Nathaniel B. Ramsey, P.S. #8396 Date  
For Ramsey Surveying

<b>RAMSEY SURVEYING</b> Professional Land Surveying Services			
283 Eby Road Shiloh, Ohio 44878 TEL (419) 512-2596 FAX (419) 522-0399 EMAIL nramsey@ramsey-surveying.com			
<b>SURVEY MADE FOR PROPERTY TRANSFER</b>			
<b>PART OF THE NORTHWEST QUARTER OF SECTION 34, MIFFLIN TOWNSHIP, T-23 N, R-17 W RICHLAND COUNTY, OHIO</b>			
DRAWN NBR	CHECKED NBR	SCALE 1" = 60'	DATE 09/27/2023
JOB NO: SM-5894			SHEET 1 OF 1

**LEGAL DESCRIPTION**

September 27, 2023

**Situated** in the Township of Mifflin, County of Richland, State of Ohio and being part of the Northwest Quarter of Section 34, Township 23-North, Range 17-West and being a parcel conveyed to AJM Properties of Mansfield, LLC by official record volume 2754, page 403 and being more particularly described as follows:

**Commencing** at an iron pin found and accepted as marking the northwest corner of said Quarter, said iron pin also marking the intersection of Pugh Road-(T.H. 299) with Crimson Road-(T.H. 296)(40' R/W);

Thence, **South 89 degrees 33 minutes 19 seconds East, 1577.96 feet** along the north line of said Quarter and along Crimson Road, to an iron pin set in the northeast corner of a parcel conveyed to David Mast, Jr. & Sarah Mast by official record volume 2947, page 259, and being the **Place of Beginning** of the parcel herein described:

Thence, the following **FOUR** courses:

1. **South 89 degrees 33 minutes 19 seconds East, 65.00 feet** continuing along the north line of said Quarter and said Crimson Road, to an iron pin set in the northwest corner of a parcel conveyed to Terri L. Davis and Richard Davis by official record volume 2963, page 176;
2. **South 02 degrees 18 minutes 15 seconds West, 293.76 feet** along the west line of said Davis parcel to an iron pin found in the northeast corner of a parcel conveyed to Neil Belcher and Glenda Belcher by official record volume 2732, page 733, and passing through an iron pin found for reference at 24.87 feet;
3. **North 89 degrees 39 minutes 28 seconds West, 65.00 feet** along the north line of said Belcher parcel to an iron pin set in the southeast corner of the aforementioned Mast parcel;
4. **North 02 degrees 18 minutes 15 seconds East, 293.88 feet** along the east line of said Mast parcel to the **Place of Beginning**, containing 0.4382 of an acre, more or less, and subject to all legal highways, leases, servitudes, use restrictions, and easements of record.

Bearings are based on an assumed meridian and are used to express angles only.

Iron pins set are 5/8" rebar with plastic cap stamped "Ramsey S-8396"

According to a survey made in September 2023 by Nathaniel B. Ramsey, Ohio Registered Professional Surveyor No. 8396.

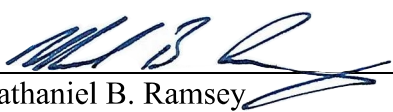
  
Nathaniel B. Ramsey  
Professional Surveyor No. 8396  
For Ramsey Surveying  
SM-5876\_Legal.docx



NEW SURVEY  
OF EXISTING PARCEL  
RICHLAND COUNTY  
TAX MAP OFFICE  
**EAK 9-29-23**

INITIAL & DATE  
**PP-273**