

EDGEWOOD ROAD - (60' R/W)

WOODHILL ROAD - (60' R/W)

Edge of Pavement

Paved Driveway

34.8'

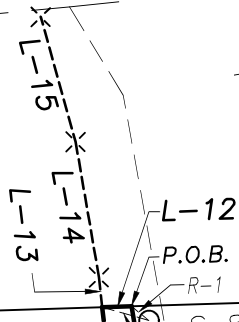

PART LOT #11039  
0.0099 Acres  
430.64 Sq. Ft

KEVIN R. KRUER & HEATHER M. TSAVARIS  
ORV. 2063, PAGE 465  
PART LOT #11039

NEW SPLIT  
RICHLAND COUNTY  
TAX MAP OFFICE  
**EAK 12-21-21**  
INITIAL DATE  
**NN-465**

GARAGE

LINE	BEARING	DISTANCE
L-1	N 78°53'56" W	3.51'
L-2	N 19°23'55" E	13.02'
L-3	N 29°39'24" W	5.21'
L-4	N 03°52'25" W	2.59'
L-5	N 12°38'34" W	10.61'
L-6	N 31°16'11" E	2.34'
L-7	N 79°48'58" E	7.32'
L-8	N 04°57'12" E	13.98'
L-9	N 19°17'22" E	16.60'
L-10	N 07°40'30" W	37.76'
L-11	N 06°11'09" W	11.55'
L-12	N 88°14'23" E	3.07'
L-13	N 06°11'09" W	3.13'
L-14	N 09°46'28" W	14.33'
L-15	N 15°35'37" W	13.52'

RUSSELL KISER II, TRUSTEE,  
OR HIS SUCCESSORS IN  
TRUST, UNDER THE R.K. II  
LIVING TRUST AS RESTATED  
ON JUNE 27, 2010  
ORV. 1994, PG. 437

PART LOT #11039

LINE	BEARING	DISTANCE
R-1	S 78°24'33" E	0.46'
R-2	S 11°06'04" W	12.10'
R-3	N 89°58'44" E	3.52'

**LEGEND**

- ✕ WOODEN STAKE FOUND
- IRON PIN/PIPE FOUND
- IRON PIN SET-5/8" REBAR SET WITH I.D. CAP STAMPED "RAMSEY S-8396"

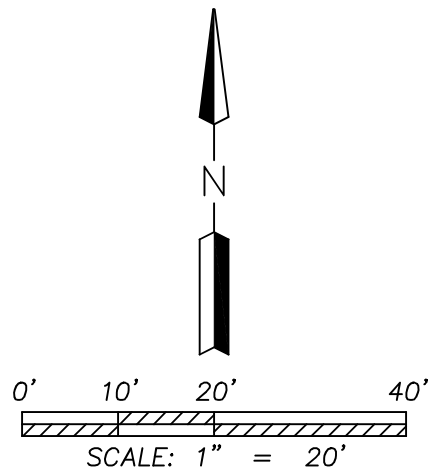

Distances shown hereon are expressed in feet and decimal parts thereof.

Bearings are to an assumed meridian and are used to express angles only.

CERTIFICATION: I hereby state that the foregoing survey was prepared from actual field measurements, in accordance with Chapter 4733-37, Ohio Administrative Code.

By: Nathaniel B. Ramsey 07/15/2021  
Nathaniel B. Ramsey, P.S. #8396 Date  
For Ramsey Surveying

**RAMSEY SURVEYING**  
Professional Land Surveying Services

283 Eby Road  
Shiloh, Ohio 44878  
TEL (419) 512-2596 FAX (419) 522-0399  
EMAIL nramsey@ramsey-surveying.com

**SURVEY EXHIBIT**

**PART OF LOT 11039, PLAT VOLUME  
15, PAGE 3 CITY OF MANSFIELD,  
RICHLAND COUNTY, OHIO**

DRAWN HCG	CHECKED NBR	SCALE 1" = 20'	DATE 07/09/2021
DWG NO: SM-5254-B			JOB NO: SM-5254
SHEET 1 OF 1			rev. 07/15/2021

## LEGAL DESCRIPTION

**Situated** in the City of Mansfield, County of Richland, State of Ohio and being part of Lot #11039 of the consecutively numbered lots in said city as recorded in plat volume 15, page 3, being a parcel conveyed to Kevin R. Kruer and Heather M. Tsavaris by official record volume 2063, page 465 of the Richland County Recorder's records, and being more particularly described as follows:

**Commencing** at the northeast corner of Lot 11039, at an iron pin found marking the westerly terminus of a curve located along the southerly existing right of way line of Edgewood Road-(60' R/W);

Thence, **South 88 degrees 14 minutes 23 seconds West, 142.20 feet**, along said southerly existing right of way line of Edgewood Road to a point referenced by an iron pin found South 78 degrees 24 minutes 33 seconds East, 0.46 feet, said point being the northwest corner of a parcel conveyed to Russell Kiser II, Trustee, or his successors in trust as restated in official record volume 1994, page 437 being the **Place of Beginning** of the parcel described herein;

Thence, the following **FOURTEEN** courses:

1. **South 08 degrees 27 minutes 28 seconds East, 42.01 feet** traversing said Lot #11039 along the west line of said Kiser parcel to an iron pipe found;
2. **South 11 degrees 06 minutes 04 seconds West, 72.11 feet** traversing said Lot #11039 along said west line to a point referenced by an iron pipe found South 11 degrees 06 minutes 04 seconds West, 12.10 feet;
3. **North 78 degrees 53 minutes 56 seconds West, 3.51 feet**, traversing aforementioned Kruer Tsavaris parcel with a new line to an iron pin set;
4. **North 19 degrees 23 minutes 55 seconds East, 13.02 feet** traversing said Kruer Tsavaris parcel with a new line to an iron pin set;
5. **North 29 degrees 39 minutes 24 seconds West, 5.21 feet** traversing said Kruer Tsavaris parcel with a new line to an iron pin set;
6. **North 03 degrees 52 minutes 25 seconds West, 2.59 feet** traversing said Kruer Tsavaris parcel with a new line to an iron pin set;
7. **North 12 degrees 38 minutes 34 seconds West, 10.61 feet** traversing said Kruer Tsavaris parcel with a new line to an iron pin set;
8. **North 31 degrees 16 minutes 11 seconds East, 2.34 feet** traversing said Kruer Tsavaris parcel with a new line to an iron pin set;
9. **North 79 degrees 48 minutes 58 seconds East, 7.32 feet** traversing said Kruer Tsavaris parcel with a new line to an iron pin set;
10. **North 04 degrees 57 minutes 12 seconds East, 13.98 feet** traversing said Kruer Tsavaris parcel with a new line to an iron pin set;
11. **North 19 degrees 17 minutes 22 seconds East, 16.60 feet** traversing said Kruer Tsavaris parcel with a new line to an iron pin set;
12. **North 07 degrees 40 minutes 30 seconds West, 37.76 feet** traversing said Kruer Tsavaris parcel with a new line to an iron pin set;

13. **North 06 degrees 11 minutes 09 seconds West, 11.55 feet** traversing said Kruer Tsavaris parcel with a new line to a point on the aforementioned south right of way line of Edgewood Road, the north line of Lot # 11039, said point being referenced by an iron pin found North 89 degrees 58 minutes 44 seconds East, 3.52 feet;
14. **North 88 degrees 14 minutes 23 seconds East, 3.07 feet** along said south right of way line, said north line of Lot # 11039 to the **Place of Beginning**, and containing 0.0099 of an acre (430.64 square feet), more or less, and subject to all legal highways, leases, servitudes, use restrictions, and easements of record.

Bearings are based on an assumed meridian and are used to express angles only.

According to a survey made in July, 2021 by Nathaniel B. Ramsey, Ohio Registered Professional Surveyor No. 8396.

The grantees, their heirs and assigns do hereby covenant and agree that the parcel of land described in this instrument does not constitute a principal building site and will not be conveyed by said grantees, heirs and assigns independent and separate from any adjoining or contiguous parcel fronting on a public highway or street.

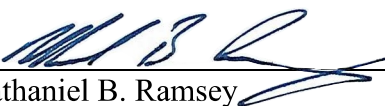
  
Nathaniel B. Ramsey  
Professional Surveyor No. 8396  
For Ramsey Surveying  
SM-5254-B\_Legal



NEW SPLIT  
RICHLAND COUNTY  
TAX MAP OFFICE  
**EAK**     **12-21-21**  
INITIAL     DATE  
**NN-465**