

APPROVED:  VILLAGE OF BELLVILLE  
 DATE: 10-19-2021

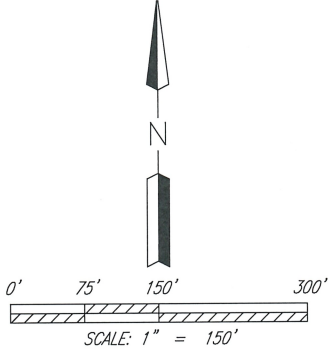
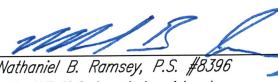

- LEGEND**
- ⊗ IRON PIN FOUND
  - Ⓜ MONUMENT BOX FOUND
  - IRON PIPE FOUND
  - △ RAILROAD SPIKE FOUND
  - ♁ MAGNAIL SPIKE FOUND
  - IRON PIN SET-5/8" REBAR SET WITH I.D. CAP STAMPED "McCartney S-7921"

Distances shown hereon are expressed in feet and decimal parts thereof.  
 Bearings are to an assumed meridian and are used to express angles only.  
 CERTIFICATION: I hereby state that the foregoing survey was prepared from actual field measurements, in accordance with Chapter 4733-37, Ohio Administrative Code.  
 By:  Nathaniel B. Ramsey, P.S. #8396 Date: 9/28/2021  
 For K.E. McCartney & Associates, Inc.

NEW SPLIT  
 RICHLAND COUNTY  
 TAX MAP OFFICE  
**EAK 10-22-21**  
 INITIAL DATE  
**NN-392**

SURVEY MADE AT THE REQUEST OF THE  
 VILLAGE OF BELLVILLE

PART OF THE SOUTHWEST QUARTER  
 OF SECTION 32, T-20 NORTH, RANGE 18 WEST,  
 WASHINGTON TOWNSHIP, VILLAGE OF BELLVILLE,  
 RICHLAND COUNTY, OHIO

DRAWN NBR	CHECKED NBR	SCALE 1" = 150'	DATE 09/28/2021
DOGPAK_LOT_SPLIT		JOB NO: GS-635	SHEET 1 OF 1

52 N. Diamond Street  
 Mansfield, OH 44902  
 T: 419-525-0093



526 E. Broad Street  
 Elyria, OH 44035  
 T: 440-323-9608

**K.E. MCCARTNEY & ASSOCIATES**  
 ENGINEERS • PLANNERS • SURVEYORS

---

**K.E. McCartney & Associates, Inc.**  

---

*Engineers • Planners • Surveyors*

**LEGAL DESCRIPTION**

**Situated** in the Village of Bellville, being a part of the Southwest Quarter of Section 32, Washington Twp., T-20, R-18, Richland County, Ohio, and being a portion of a parcel conveyed to J.C. Gorman, Trustee by official record volume 2417, page 703 and being more particularly described as follows:

**Beginning** for the same a monument box found marking the intersection of the south line of said Quarter with the centerline of RIC-Bikeway (PB. 26, PG. 91);

Thence, the following **SIX** Courses:

1. **South 89 degrees 28 minutes 51 seconds West, 460.77 feet** along the south line of said quarter to an iron pin set;
2. **North 15 degrees 24 minutes 20 seconds West, 911.33 feet**, traversing the aforementioned J.C. Gorman Trustee parcel to an iron pin set;
3. **North 89 degrees 28 minutes 51 seconds East, 216.35 feet**, traversing said J.C. Gorman Trustee parcel to an iron pin set on the easterly existing right of way line of the Richland County Bike Trail;
4. Along a non-tangential curve to the right with a **radius of 4944.15 feet, a delta angle of 01 degrees 20 minutes 23 seconds an arc length of 115.61 feet, a chord bearing of South 31 degrees 30 minutes 55 seconds East, and a chord distance of 115.61 feet** along said easterly existing right of way line to an iron pin found;
5. **South 30 degrees 50 minutes 44 seconds East, 905.56 feet** continuing along said easterly existing right of way line to an iron pin set on the south line of said quarter;
6. **South 89 degrees 28 minutes 51 seconds West, 38.23 feet** along said south line to the **Place of Beginning** and containing a total of 7.2465 Acres, more or less, of which 1.9594 acres are located within existing bike trail and highway right of way, resulting in a net area of 5.2871 acres, more or less, and subject to all legal highways, easements, leases, and use restrictions of record.

Bearings are based on an assumed meridian and are used to denote angular variations.

This area contained within Auditor Parcel No. 0606300103000

Iron pins set are 5/8" rebar with plastic cap stamped "McCartney S-7921"

According to survey by Nathaniel B. Ramsey P.S. 8396 made September 2021 for K.E. McCartney & Associates, Inc.

Deed citations made herein are referenced to the Richland County Recorder's records.

  
\_\_\_\_\_  
Nathaniel B. Ramsey P.S.  
Ohio Registered Surveyor No. S-8396  
For K.E. McCartney & Associates, Inc.



Approved  \_\_\_\_\_  
Village of Bellville Administrator  
Title

NEW SPLIT  
RICHLAND COUNTY  
TAX MAP OFFICE  
**EAK** **10-22-21**  
\_\_\_\_\_  
INITIAL DATE  
**NN-392**