

NEW SURVEY
OF EXISTING PARCEL
RICHLAND COUNTY
TAX MAP OFFICE
EAK **9-23-21**
INITIAL DATE
NN-374

- LEGEND**
- IRON PIPE FOUND
 - △ MAGNAIL SPIKE FOUND
 - IRON PIN FOUND

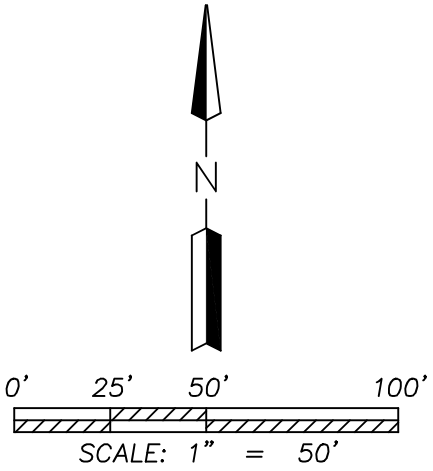

Distances shown hereon are expressed in feet and decimal parts thereof.

Bearings are to an assumed meridian and are used to express angles only.

CERTIFICATION: I hereby state that the foregoing survey was prepared from actual field measurements, in accordance with Chapter 4733-37, Ohio Administrative Code.

RAMSEY SURVEYING
Professional Land Surveying Services

283 Eby Road
Shiloh, Ohio 44878
TEL (419) 512-2596, FAX (419) 522-0399
EMAIL nramsey@ramsey-surveying.com

**SURVEY MADE AT THE REQUEST OF
KELLIN R. STURTS**

**PART OF THE NORTHWEST QUARTER
OF SECTION 19, SPRINGFIELD TOWNSHIP
T-21 N, R-19 W
RICHLAND COUNTY, OHIO**

DRAWN NBR	CHECKED	SCALE 1" = 50'	DATE 09/17/2021
JOB NO: SM-5618			SHEET 1 OF 1

By: Nathaniel B. Ramsey 09/17/2021
Nathaniel B. Ramsey, P.S. #8396 Date
For Ramsey Surveying

RAMSEY SURVEYING
Professional Land Surveying Services

283 Eby Road
Shiloh, Ohio 44878
TEL (419) 512-2596
FAX (419) 522-0399
EMAIL nramsey@ramsey-surveying.com

September 17, 2021

LEGAL DESCRIPTION

Situated in the State of Ohio, County of Richland, Township of Springfield; being a part of the Northwest Quarter of Section 19, Township 21-North, Range 19-West, and being land conveyed to Kellin R. & Tarin M. Sturts by official record volume 2702, page 337, being more particularly described as follows:

Commencing at an iron pin found and accepted as marking the northwest corner of said Northwest Quarter;

Thence **North 87 degrees 29 minutes 50 seconds East, 1198.37 feet** along the north line of said Quarter to an iron pin found in the northeast corner of a parcel conveyed to Timothy A. & Shawaunia K. Scott by official record volume 2889, page 865, and being the **Place of Beginning** of the parcel described herein;

Thence, the following **FOUR** Courses:

1. **South 87 degrees 29 minutes 50 seconds East, 109.90 feet** continuing along said north line of said Quarter to an iron pipe found in the northwest corner of a parcel conveyed to Joseph M. & Laurie A. Kehres by official record volume 155, page 978;
2. **South 01 degree 02 minutes 10 seconds West, 190.70 feet** along the west line of said Kehres parcel to an iron pin found in the southwest corner thereof, said iron pin also being on the north existing right of way line of Crestline-Ontario Road-(SR 181)(ORV. 822, Pg. 200);
3. **North 72 degrees 30 minutes 27 seconds West, 114.62 feet** along said north right of way line to an iron pin found in the southeast corner of the aforementioned Scott parcel;
4. **North 01 degree 03 minutes 36 seconds East, 161.04 feet** along the east line of said Scott parcel to the **Place of Beginning**, containing 0.4437 of an acre, more or less, and subject to all legal highways, easements, leases, and use restrictions of record.

Bearings are based on an assumed meridian and are used to express angles only.

According to a survey made in September 2021 by Nathaniel B. Ramsey, Ohio Registered Professional Surveyor No. 8396

NEW SURVEY
OF EXISTING PARCEL
RICHLAND COUNTY
TAX MAP OFFICE
EAK **9-23-21**
INITIAL DATE
NN-374

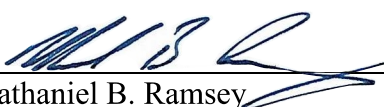

Nathaniel B. Ramsey

Professional Surveyor No. 8396
For Ramsey Surveying
SM-5618 legal.docx