

**REPLACED BY OO-149**

NELSON Z. & ESTHER M. MARTIN  
ORV. 2308, PG. 717

ELMER B. & RUTH ANN SENSENIG  
ORV. 1607, PG. 874

**NEW SPLIT  
RICHLAND COUNTY  
TAX MAP OFFICE**  
EAK 7-19-19  
INITIAL DATE  
LL-182

**LEGEND**

- IRON PIN/PIPE FOUND
- △ MAGNAIL SPIKE FOUND
- IRON PIN SET-5/8" REBAR  
SET WITH I.D. CAP STAMPED  
"RAMSEY S-8396"
- ⊗ 2" MAGNAIL SPIKE SET
- ⊗ SURVEY SPIKE FOUND

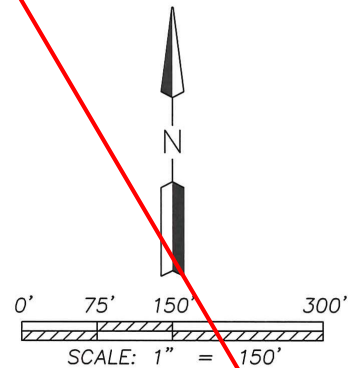

Distances shown hereon are expressed in feet and decimal parts thereof.

Bearings are to an assumed meridian and are used to express angles only.

CERTIFICATION: I hereby state that the foregoing survey was prepared from actual field measurements, in accordance with Chapter 4733-37, Ohio Administrative Code.

B.S. Nathaniel B. Ramsey, P.S. #8396 6/18/2019 Date  
For Ramsey Surveying

**RAMSEY SURVEYING**  
Professional Land Surveying Services  
283 Eby Road  
Shiloh, Ohio 44878  
TEL (419) 512-2596 FAX (419) 522-0399  
EMAIL nramsey@ramsey-surveying.com

---

**SURVEY MADE FOR  
PROPERTY TRANSFER**

---

**PART OF THE NORTHEAST QUARTER  
OF SECTION 2, BUTLER TOWNSHIP  
T-23 N, R-18 W  
RICHLAND COUNTY, OHIO**

DRAWN NBR	CHECKED NBR	SCALE 1" = 150'	DATE 6/18/2019
--------------	----------------	--------------------	-------------------

JOB NO: SM-5337 SHEET 1 OF 1

**REPLACED BY 00-149**

**LEGAL DESCRIPTION**

**Situated** in the Township of Butler, County of Richland, State of Ohio and being a part of the Northeast Quarter of Section 2, Township 23-North, Range 18-West, being a portion of a parcel conveyed to Elmer B. & Ruth Ann Sensenig by official record volume 1607, page 874 and being more particularly described as follows:

**Beginning** for the same at a survey spike found and accepted as marking the intersection of the centerline of Olivesburg-Fitchville Road-(C.H. 77) with the centerline of Baseline Road-(C.H. 11), said spike also being on the north line of the Northeast Quarter of Section 2;

Thence, **South 21 degrees 41 minutes 34 seconds East, 1571.17 feet** along the centerline of Olivesburg-Fitchville Road to a Magnail spike found in the northeast corner of said Sensenig parcel and being the Place of Beginning of the parcel herein described;

Thence, the following **FOUR** courses:

1. **South 21 degrees 41 minutes 34 seconds East, 449.82 feet** continuing along said centerline to a Magnail spike set;
2. **North 87 degrees 24 minutes 14 seconds West, 575.03 feet** to an iron pin set, and passing through an iron pin set for reference at 30.00 feet;
3. **North 02 degrees 35 minutes 46 seconds East, 410.00 feet** to an iron pin set on a north line of said Sensenig parcel;
4. **South 87 degrees 24 minutes 14 seconds East, 390.00 feet** along said north line to the **Place of Beginning**, and passing through an iron pipe found for reference at 360.00 feet, and containing 4.542 of an acre, more or less, and subject to all legal highways, leases, servitudes, use restrictions, and easements of record.

Bearings are based on an assumed meridian and are used to express angles only.

According to a survey made in July 2019 by Nathaniel B. Ramsey, Ohio Registered Professional Surveyor No. 8396.

  
Nathaniel B. Ramsey  
Professional Surveyor No. 8396  
For Ramsey Surveying  
SM-5337.docx



NEW SPLIT  
RICHLAND COUNTY  
TAX MAP OFFICE  
**EAK 7-19-19**  
INITIAL DATE  
**LL-182**