

CURVE "A"
 L=109.30'
 R=7262.82'
 Δ=0°51'44"
 CH. BRG.=S 17°26'42" W
 CH. DIST.=109.30'

CURVE "B"
 L=100.00'
 R=7262.82'
 Δ=0°47'20"
 CH. BRG.=N 16°37'10" E
 CH. DIST.=100.00'

NEW SURVEY
 OF EXISTING PARCEL
 RICHLAND COUNTY
 TAX MAP OFFICE
EAK 12-17-12
 INITIAL DATE
 dd-299

DR. ROD L. & SUSAN E. STAKER
 DV. 794, PG. 293

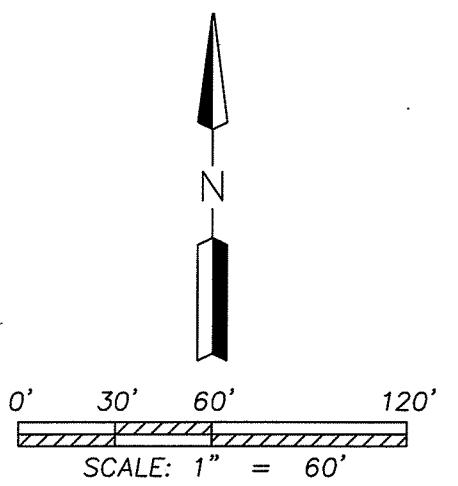

LEGEND

- ◆ CONCRETE RIGHT OF WAY MONUMENT FOUND
- IRON PIN/PIPE FOUND
- △ ANGLE IRON FOUND
- IRON PIN SET-5/8" REBAR SET WITH I.D. CAP STAMPED "RAMSEY S-8396"

Distances shown hereon are expressed in feet and decimal parts thereof.

Bearings are based on survey J-440 on file at the Richland County Tax Map Office and are used to express angles only.

CERTIFICATION: I hereby state that the foregoing survey was prepared from actual field measurements, in accordance with Chapter 4733-37, Ohio Administrative Code.

By: Nathaniel B. Ramsey 12/17/2012
 Nathaniel B. Ramsey, P.S. #8396 Date
 For Ramsey Surveying

RAMSEY SURVEYING
 Professional Land Surveying Services
 283 Eby Road
 Shiloh, Ohio 44878
 TEL (419) 512-2596 FAX (419) 522-0399
 EMAIL nramsey@ramsey-surveying.com

SURVEY MADE FOR
PROPERTY TRANSFER

PART OF THE NORTHWEST QUARTER
OF SECTION 18, WASHINGTON TOWNSHIP
T-20 N, R-18 W
RICHLAND COUNTY, OHIO

DRAWN MER	CHECKED PJR	SCALE 1" = 60'	DATE 12/17/2012
JOB NO: SM-5030			SHEET 1 OF 1

RAMSEY SURVEYING
Professional Land Surveying Services

283 Eby Road
Shiloh, Ohio 44878
TEL (419) 512-2596
FAX (419) 522-0399
EMAIL nramsey@ramsey-surveying.com

December 17, 2012

LEGAL DESCRIPTION

Situated in the Township of Washington, County of Richland, State of Ohio, being a part of the Northwest Quarter of Section 18, Township 20, North, Range 18, West, and being more particularly described as follows:

Commencing at a point in the southeast corner of Meadow Lane Allotment as recorded in Plat Volume 17, page 61 of the Richland County Recorder's Records, and being on the centerline of Lexington Avenue, U.S.R. 42 (60' R/W), said point being referenced by an iron pin found North 87 degrees 20 minutes 07 seconds West, 31.10 feet from said point;

Thence, South 17 degrees 52 minutes 34 seconds West, 684.52 feet with said centerline of Lexington Avenue, U.S.R. 42 (60' R/W) to a point of curvature, said point being referenced by a concrete right of way monument found North 74 degrees 49 minutes 53 seconds West, 29.97 feet from said point;

Thence, along a curve to the left having a radius of 7262.82 feet, a delta angle of 00 degrees 51 minutes 44 seconds, an arc length of 109.30 feet, a chord bearing of South 17 degrees 26 minutes 42 seconds West, and a chord distance of 109.30 feet to a point in the southwesterly corner of a parcel conveyed to James P. Morr by official record volume 1922, page 649, said point also being the northwesterly corner of a parcel conveyed to Margaret E. Edmundson by official record volume 2181, page 637, and being **the place of beginning** of the parcel herein described;

Thence with the following **FOUR** courses:

1. **South 69 degrees 56 minutes 35 seconds East, 386.19 feet** with the southerly line of said Morr parcel, the same being the northerly line of said Edmundson parcel to an iron pin found in the easterly common corner thereof, said iron pin also being on a westerly line of a parcel conveyed to Dr. Rod L. & Susan E. Staker by deed volume 749, page 293, and passing through an iron pin set for reference at 30.00 feet;
2. **South 14 degrees 23 minutes 18 seconds West, 100.00 feet** with the easterly line of said Edmundson, the same being a westerly line of said Staker parcel to an angle iron found in the southeasterly corner of said Edmundson parcel, said angle iron also being in the northeasterly corner of a parcel conveyed to James A. Reed by deed volume 745, page 126;
3. **North 69 degrees 59 minutes 19 seconds West, 390.07 feet** with the southerly line of said Edmundson parcel, the same being the northerly line of said Reed parcel to a point in

the westerly common corner thereof, said point also being on said centerline of Lexington Avenue, U.S.R. 42 (60' R/W), and passing through an iron pin set for reference at 360.07 feet;

4. **Northeasterly** with a said centerline of Lexington Avenue, U.S.R. 42 (60' R/W) and along a curve to the right having a **radius of 7262.82 feet, a delta angle of 00 degrees 47 minutes 20 seconds, an arc length of 100.00 feet, a chord bearing of North 16 degrees 37 minutes 10 seconds East, and a chord distance of 100.00 feet** to the place **of beginning** and containing 0.888 of an acre, more or less, and subject to all legal highways, easements, leases, servitudes, and use restrictions of record.

Iron pins set are 5/8" diameter rod with plastic cap stamped "Ramsey S-8396".

Bearings are based on survey J-440 on file at the Richland County Tax Map Office and are used to express angles only.

According to a survey made in December, 2012 by Nathaniel B. Ramsey, Ohio Registered Professional Surveyor No. 8396.

The intent of this instrument is to describe in greater detail the premises described in official record volume 2181, page 637.



Nathaniel B. Ramsey
Professional Surveyor No. 8396
For Ramsey Surveying
SM-5030



NEW SURVEY
OF EXISTING PARCEL
RICHLAND COUNTY
TAX MAP OFFICE
EAK 17-17-12
INITIAL DATE
dd-299