

TYPICAL BRICK PROJECTION
ALONG NORTH PROPERTY LINE

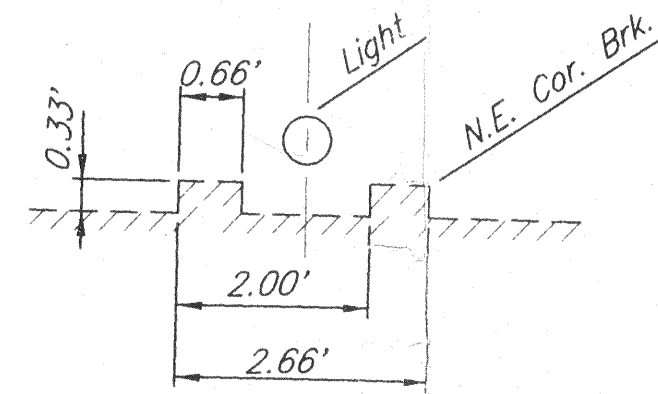

No Scale

TYPICAL BRICK PROJECTION
ALONG SOUTH PROPERTY LINE

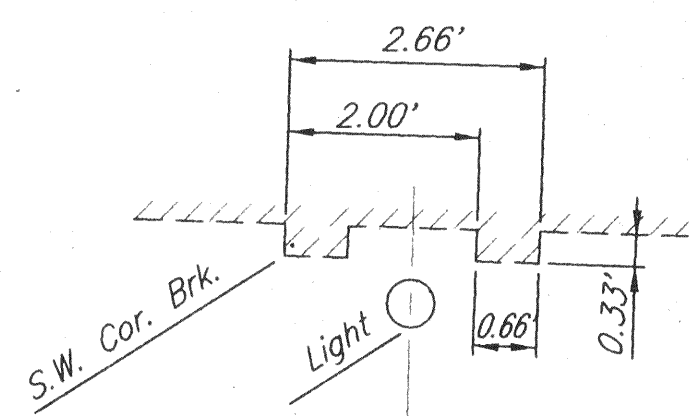

No Scale

ENCROACHMENT DETAIL C
SEARS AUTO CENTER BLDG.

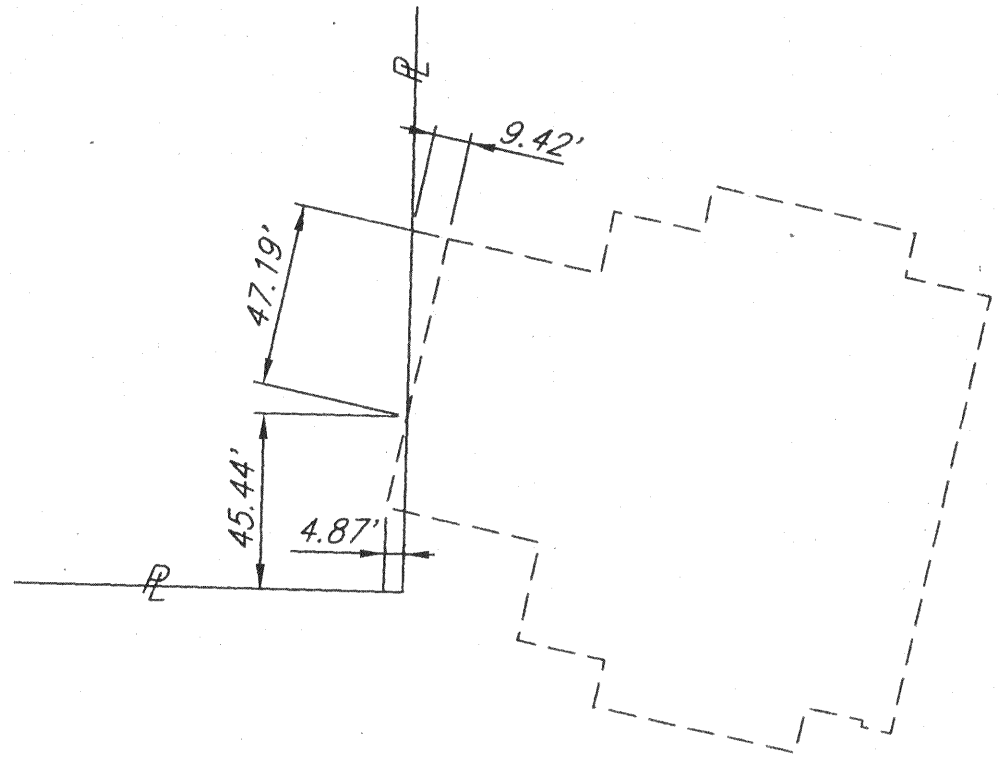

Scale 1"=50'

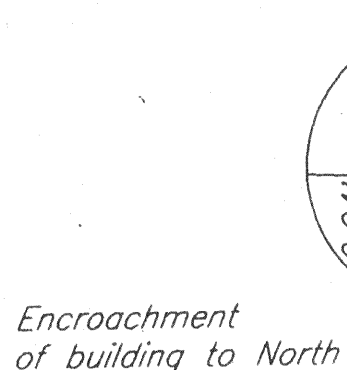

Encroachment of building to North

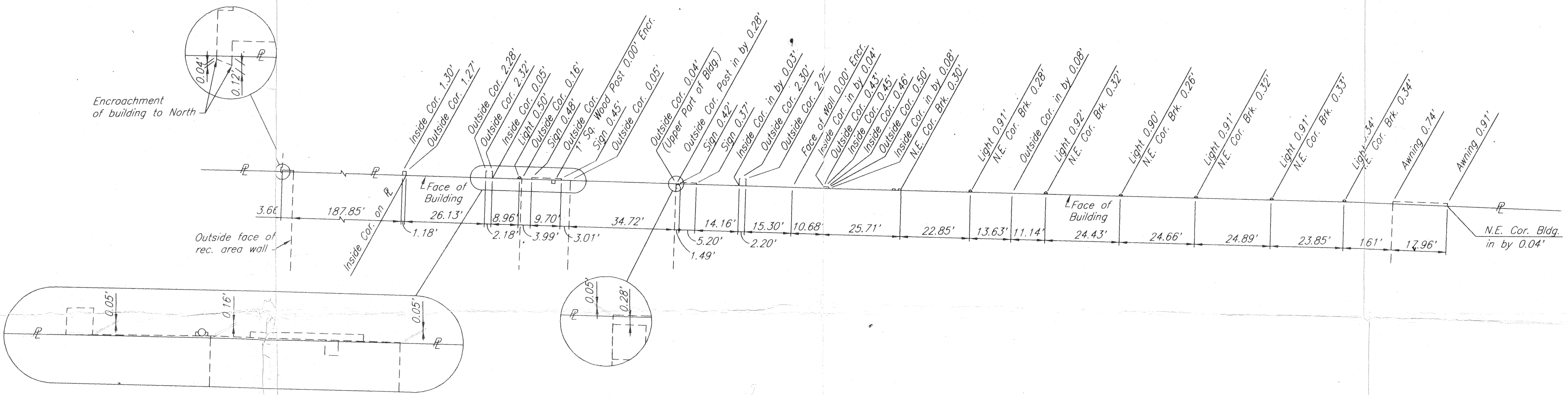

ENCROACHMENT DETAIL A
ALONG NORTH PROPERTY LINE

Scale 1"=20'

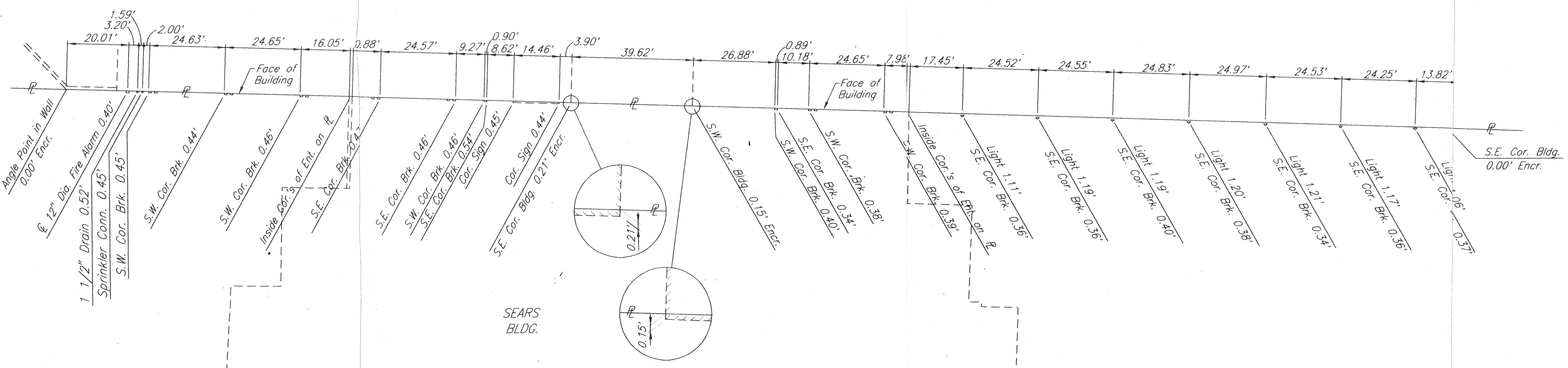

ENCROACHMENT DETAIL B
ALONG SOUTH PROPERTY LINE

Scale 1"=20'

RECEIVED
APPROVED
DEC 02 1994
Cal Miller
ZONING INSPECTOR
VILLAGE OF ONTARIO, OHIO

REL RICHLAND ENGINEERING LIMITED
MANSFIELD, OHIO

SURVEY OF MANSFIELD JOINT VENTURE
PROPERTY AT RICHLAND MALL
BOUNDARY DRAWING
ENCROACHMENT DETAILS
VILLAGE OF ONTARIO
COUNTY OF RICHLAND
STATE OF OHIO

DESIGNED	DRAWN	TRACED	CHECKED	REVIEWED	DATE	REVISED
						7/22/94

2 / 4